



**Product Manual 26546V1
(Revision H, 8/2023)
Original Instructions**



ProTech®-SX

Manual 26546 consists of two volumes (26546V1 & 26546V2)

Volume-Installation and Operation Manual

	General	Read this entire manual and all other publications pertaining to the work to be performed before installing, operating, or servicing this equipment.
	Precautions	Practice all plant and safety instructions and precautions.
		Failure to follow instructions can cause personal injury and/or property damage.

	Revisions	This publication may have been revised or updated since this copy was produced. The latest version of most publications is available on the Woodward website.
		http://www.woodward.com
		If your publication is not there, please contact your customer service representative to get the latest copy.

	Proper Use	Any unauthorized modifications to or use of this equipment outside its specified mechanical, electrical, or other operating limits may cause personal injury and/or property damage, including damage to the equipment. Any such unauthorized modifications: (i) constitute "misuse" and/or "negligence" within the meaning of the product warranty thereby excluding warranty coverage for any resulting damage, and (ii) invalidate product certifications or listings.

	Translated Publications	If the cover of this publication states "Translation of the Original Instructions" please note:
		The original source of this publication may have been updated since this translation was made. The latest version of most publications is available on the Woodward website.
		www.woodward.com/publications
		Always compare with the original for technical specifications and for proper and safe installation and operation procedures.
		If your publication is not on the Woodward website, please contact your customer service representative to get the latest copy.

Revisions— A bold, black line alongside the text identifies changes in this publication since the last revision.

Woodward reserves the right to update any portion of this publication at any time. Information provided by Woodward is believed to be correct and reliable. However, no responsibility is assumed by Woodward unless otherwise expressly undertaken.

Contents

WARNINGS AND NOTICES	5
ELECTROSTATIC DISCHARGE AWARENESS.....	6
REGULATORY COMPLIANCE.....	7
SAFETY SYMBOLS	11
CHAPTER 1. GENERAL INFORMATION	12
Description	12
Applications.....	13
CHAPTER 2. INSTALLATION.....	15
Introduction	15
Unpacking	15
System Installation Procedure	15
Enclosures.....	16
Mounting Location Considerations.....	18
Environmental Specifications.....	19
Power Supply Requirements.....	19
Input/Output Signal Specifications	21
Shielded Wiring.....	24
Control Wiring Guidelines	24
CHAPTER 3. FUNCTIONALITY.....	38
Features	38
Programming/Configuring Overview.....	38
Product Models	39
Inputs and Outputs.....	40
Overspeed and Over-Acceleration Detection and Trip	43
Start Logic	44
Configurable Logic	46
Test Routines	47
Alarm, Trip, and Event Latches.....	49
System Logs	51
Response Time Performance	52
CHAPTER 4. MODBUS COMMUNICATIONS	54
Modbus Communications.....	54
Monitor Only.....	54
Monitor and Control.....	54
Modbus Communication	54
Port Adjustments.....	55
ProTech-SX Parameter Addresses.....	55
CHAPTER 5. TROUBLESHOOTING	61
I/O Troubleshooting.....	62
Trip Indications.....	66
Alarm Indications.....	68
CHAPTER 6. SAFETY MANAGEMENT	71
Product Variations Certified	71
Safe State.....	71
SIL Specifications.....	71
Failure Rate Data	72
Response Time Data	72
Limitations	72
Management of Functional Safety	72

Restrictions	73
Competence of Personnel.....	73
Operation and Maintenance Practice.....	73
Installation and Site Acceptance Testing.....	73
Functional Testing after Initial Installation.....	73
Functional Testing after Changes	73
Proof Testing (Functional Test).....	73
CHAPTER 7. ASSET MANAGEMENT.....	75
Product Storage Recommendations	75
Refurbishment Period Recommendation	75
CHAPTER 8. PRODUCT SUPPORT AND SERVICE OPTIONS	76
Product Support Options.....	76
Product Service Options	76
Returning Equipment for Repair	77
Replacement Parts.....	78
Engineering Services	78
Contacting Woodward's Support Organization.....	78
Technical Assistance	79
APPENDIX. MODBUS ETHERNET GATEWAY INFORMATION.....	80
Introduction	80
B&B Electronics Setup.....	80
Lantronix Setup	84
REVISION HISTORY	89
DECLARATIONS	90

Illustrations and Tables

Figure 1-1. Typical ProTech-SX Application	13
Figure 1-2. Typical Gas Turbine Application	14
Figure 1-3. Typical Safety PLC Application	14
Figure 2-1a. Typical ProTech-SX Panel Mount Package—Front View	16
Figure 2-1b. Typical ProTech-SX Panel Mount Package—Rear View with Cover	16
Figure 2-2a. Mounting Outline Diagram for ProTech-SX Panel-Mount Models.....	17
Figure 2-2b. Mounting Outline Diagram for ProTech-SX Panel-Mount Models.....	18
Figure 2-3. Screw Connection Terminal Block.....	25
Figure 2-4. ProTech-SX Control Wiring Diagram.....	27
Figure 2-5a. Example MPU (Passive Magnetic Pickup Unit) Wiring	28
Figure 2-5b. Example Proximity Probe (Active Magnetic Pickup Unit) Wiring (Internal Power).....	28
Figure 2-5c. Example Proximity Probe (Active Magnetic Pickup Unit) Wiring (External Power, Non-preferred).....	29
Figure 2-5d. Example Eddy Current Probe (Active Magnetic Pickup Unit) Wiring	29
Figure 2-6a. Example Standard Discrete Input Wiring (Internal Power Option)	30
Figure 2-6b. Example Standard Discrete Input Wiring (External Power Option).....	30
Figure 2-7a. Example Configurable Input Wiring—Discrete Input (Internal Power Option)	31
Figure 2-7b. Example Configurable Input Wiring—Discrete Input (External Power Option)	32
Figure 2-8. Example Configurable Input Wiring—Analog Input	32
Figure 2-9. Example Analog Output Wiring	33
Figure 2-10a. Example Trip Relay Wiring (Internal Supply)	33
Figure 2-10b. Example Trip Relay Wiring (External Supply)	34
Figure 2-10c. Example Programmable Relay Wiring (Internal Supply)	34
Figure 2-10d. Example Programmable Relay Wiring (External Supply).....	35
Figure 2-11. Power Supply Relationship Diagram	36
Figure 2-12a. Serial Port Interface Diagram—RS-232	36
Figure 2-12b. Serial Com Port Interface Diagram—RS-485.....	37
Figure 2-13. Service Tool Cable/Interface Diagram	37
Figure 3-1. Basic Functional Overview	39
Figure 3-2. Functional Diagram of ProTech-SX module	40
Figure 3-3. Discrete Input Example	42
Figure 3-4. Analog Input Example	42
Figure 3-5. Programmable Relay Output Diagram	43
Figure 3-6. Over-Acceleration Enabling Diagram	44
Figure 3-7. Speed Fail Trip Diagram.....	45
Figure 3-8. Speed Fail Timeout Trip Diagram.....	45
Figure 3-9. Response Time Definition	52
Figure 3-10. Trip Relay Response Time (Typical) Graph	53
Figure 6-1. Trip Response Time	72
Figure A-1. RS-232 Wiring Diagram	81
Figure A-2. RS-485 2-Wire.....	81
Figure A-3. Lantronix RS-232 Connection	84
Figure A-4. Lantronix RS-485 Multi-drop Connection.....	85

Table 1-1. Available ProTech-SX Models	12
Table 2-1. Environmental Specifications.....	19
Table 2-2. Power Supply Specifications	19
Table 2-3. High Voltage Input Specifications.....	19
Table 2-4. Low Voltage Input Specifications.....	19
Table 2-5. Signal Input Power Supply Specifications	20
Table 2-6. Relay Output Power Supply Specifications	20
Table 2-7. General Input Specifications.....	21
Table 2-8. Passive Speed Probe Specifications	21
Table 2-9. Active Speed Probe Specifications.....	21
Table 2-10. Dedicated Discrete Input Specifications	22
Table 2-11. General Input Specifications.....	22
Table 2-12. Analog Input Specifications	22
Table 2-13. Discrete Input Specifications	23
Table 2-14. Trip Relay Output Specifications	23
Table 2-15. Programmable Relay Output Specifications	23
Table 2-16. Analog Output Specifications.....	23
Table 2-17. Serial Communications Port Specifications.....	23
Table 4-1. Supported Modbus Function Codes	54
Table 4-2. Modbus Communication Port Settings	55
Table 4-3. Boolean Write Addresses (Code 05)	56
Table 4-4. Boolean Read Addresses (Code 02).....	57
Table 4-5. Analog Read Addresses (Code 04).....	59
Table 6-1. Initial Power-up States	71
Table 6-2. SIL 2 Values.....	71
Table 6-3. Failure Rate Data.....	72
Table 6-4. Response Time Data	72

Warnings and Notices

Important Definitions



This is the safety alert symbol used to alert you to potential personal injury hazards. Obey all safety messages that follow this symbol to avoid possible injury or death.

- **DANGER** - Indicates a hazardous situation, which if not avoided, will result in death or serious injury.
- **WARNING** - Indicates a hazardous situation, which if not avoided, could result in death or serious injury.
- **CAUTION** - Indicates a hazardous situation, which if not avoided, could result in minor or moderate injury.
- **NOTICE** - Indicates a hazard that could result in property damage only (including damage to the control).
- **IMPORTANT** - Designates an operating tip or maintenance suggestion.

WARNING

Overspeed / Overtemperature / Overpressure

The engine, turbine, or other type of prime mover should be equipped with an overspeed shutdown device to protect against runaway or damage to the prime mover with possible personal injury, loss of life, or property damage.

The overspeed shutdown device must be totally independent of the prime mover control system. An overtemperature or overpressure shutdown device may also be needed for safety, as appropriate.

WARNING

Personal Protective Equipment

The products described in this publication may present risks that could lead to personal injury, loss of life, or property damage. Always wear the appropriate personal protective equipment (PPE) for the job at hand. Equipment that should be considered includes but is not limited to:

- Eye Protection
- Hearing Protection
- Hard Hat
- Gloves
- Safety Boots
- Respirator

Always read the proper Material Safety Data Sheet (MSDS) for any working fluid(s) and comply with recommended safety equipment.

WARNING

Start-up

Be prepared to make an emergency shutdown when starting the engine, turbine, or other type of prime mover, to protect against runaway or overspeed with possible personal injury, loss of life, or property damage.

WARNING

Automotive Applications

On- and off-highway Mobile Applications: Unless Woodward's control functions as the supervisory control, customer should install a system totally independent of the prime mover control system that monitors for supervisory control of engine (and takes appropriate action if supervisory control is lost) to protect against loss of engine control with possible personal injury, loss of life, or property damage.

NOTICE**Battery Charging
Device**

To prevent damage to a control system that uses an alternator or battery-charging device, make sure the charging device is turned off before disconnecting the battery from the system.

Electrostatic Discharge Awareness

NOTICE**Electrostatic
Precautions**

Electronic controls contain static-sensitive parts. Observe the following precautions to prevent damage to these parts:

- Discharge body static before handling the control (with power to the control turned off, contact a grounded surface and maintain contact while handling the control).
- Avoid all plastic, vinyl, and Styrofoam (except antistatic versions) around printed circuit boards.
- Do not touch the components or conductors on a printed circuit board with your hands or with conductive devices.

To prevent damage to electronic components caused by improper handling, read and observe the precautions in Woodward manual **82715**, *Guide for Handling and Protection of Electronic Controls, Printed Circuit Boards, and Modules*.

Follow these precautions when working with or near the control.

1. Avoid the build-up of static electricity on your body by not wearing clothing made of synthetic materials. Wear cotton or cotton-blend materials as much as possible because these do not store static electric charges as much as synthetics.
2. Do not remove the printed circuit board (PCB) from the control cabinet unless absolutely necessary. If you must remove the PCB from the control cabinet, follow these precautions:
 - Do not touch any part of the PCB except the edges.
 - Do not touch the electrical conductors, the connectors, or the components with conductive devices or with your hands.
 - When replacing a PCB, keep the new PCB in the plastic antistatic protective bag it comes in until you are ready to install it. Immediately after removing the old PCB from the control cabinet, place it in the antistatic protective bag.

Regulatory Compliance

European Compliance for CE Marking

These listings apply to stationary industrial markets only and are limited only to those units bearing the CE Marking.

EMC Directive: Declared to Directive 2014/30/EU of the European Parliament and of the Council of 26 February 2014 on the harmonization of the laws of the Member States relating to electromagnetic compatibility (EMC).

Low Voltage Directive: Directive 2014/35/EU on the harmonisation of the laws of the Member States relating to making electrical equipment available on the market, designed for use within certain voltage limits.

ATEX Directive: Directive 2014/34/EU on the harmonisation of the laws of the Member States relating to equipment and protective systems intended for use in potentially explosive atmospheres.
 II 3 G, Ex ec nC IIC T4 Gc

Other European Compliance

Compliance with the following European Directives or standards does not qualify this product for application of the CE Marking:

RoHS Directive: Restriction of Hazardous Substances 2011/65/EU:
 Woodward Turbomachinery Systems products are intended exclusively for sale and use only as a part of Large Scale Fixed Installations per the meaning of Art.2.4(e) of directive 2011/65/EU. This fulfills the requirements stated in Art.2.4(c) and as such the product is excluded from the scope of RoHS2.

United Kingdom Compliance for UKCA Marking

These listings are limited only to those units bearing the UKCA Marking.

S.I. 2016 No. 1107 Equipment and Protective Systems Intended for use in Potentially Explosive Atmospheres Regulations 2016
 II 3 G, Ex ec nC IIC T4 Gc

S.I. 2016 No. 1091 Electromagnetic Compatibility Regulations 2016

S.I. 2016 No. 1101 The Electrical Equipment (Safety) Regulations 2016

Other UKCA Compliance

Compliance with the following UKCA regulations or standards does not qualify this product for application of the UKCA Marking:

Hazardous Substances and Packaging: S.I. 2020 No. 1647: The Hazardous Substances and Packaging (Legislative Functions and Amendments) (EU Exit) Regulations 2020.

This product is intended to be sold and used only as equipment which is specifically designed, and is to be installed, as part of another type of equipment that is excluded or does not fall within the scope of this Regulation, which can fulfil its function only if it is part of that equipment, and which can be replaced only by the same specifically designed equipment and therefore fulfills the requirements stated in Part 2 of Schedule1 clause 16 and as such is excluded from the scope of the Regulation.

This product is intended to be sold and used only as repair, updating or upgrading of EEE (as defined in part 3 of schedule 1) that either was excluded from the scope of the Directive at the time of placing on the market (as defined in Schedule 1, part 2) or which benefited from an exemption and which was placed on the market before that exemption expired (per schedule 1 part 3).

Other International Compliance

Australia (& New Zealand)

RCM: Compliance is limited to application for those units bearing the Regulatory Compliance Mark (RCM). *Only EMC is applicable in virtually all Woodward intended applications.*
RCM on WWD products is very limited due to allowed exemptions from applying the RCM or having a DoC.

EMC: Electromagnetic Compatibility (EMC) Declaration of Conformity (DoC) RCM requirements for the Australian (& New Zealand) Radiocommunications Act is a separate document only created for products applying the RCM to the label.
Products with RCM on the label have an EMC Declaration of Conformity available:
Woodward products typically comply with at least CISPR11 Group1, Class A emissions limits, Electromagnetic Interference (EMI) testing, even if not marked with the RCM: *as long as the "CE mark" is on the label.*

TÜV: TÜV certified for SIL-2 per IEC 61508 Parts 1-7, Functional Safety of Electrical / Electronic / Programmable Electronic Safety Related Systems.

North American Compliance

CSA: Certified for Class I, Division 2, Groups A, B, C, and D, T4 at 60 °C Ambient for use in the United States and Canada.
Certificate 160584-2217246

Other Compliance

Gas Corrosion: IEC60068-2-60:1995 Part 2.60 Methods 1 and 4 (conformal coating)

Machinery Protection: API670, API612, & API-611 compliant

Special Conditions for Safe Use

This equipment is suitable for use in Class I, Division 2, Groups A, B, C, D or non-hazardous locations only.

This equipment is suitable for use in European Zone 2, Group IIC environments or non-hazardous locations only.

For hazardous location installations, wiring must be in accordance with North American Class I, Division 2, or European Zone 2, Category 3 wiring methods as applicable, and in accordance with the authority having jurisdiction.



Due to the Hazardous Location Listings associated with this product, proper wire type and wiring practices are critical to the operation.

Explosion Hazard

A fixed wiring installation is required, and a switch or circuit breaker shall be included in the building installation that is in close proximity to the equipment and within easy reach of the operator and that is clearly marked as the disconnecting device for the equipment. The switch or circuit breaker shall not interrupt the protective earth conductor.

Protective Earth Grounding is required by the input PE terminal.

Field wiring must be rated at least 85 °C for operating ambient temperatures expected to exceed 60° C.

The risk of electrostatic discharge is reduced by permanent installation of this device, proper connection of the equipotential ground lugs, and care when cleaning. This device must not be cleaned or wiped off/against unless the area is known to be non-hazardous.



The external ground lugs shown on the installation drawing must be properly connected to ensure equipotential bonding. This will reduce the risk of electrostatic discharge in an explosive atmosphere.

Explosion Hazard

Cleaning by hand or water spray must be performed while the area is known to be non-hazardous to prevent an electrostatic discharge in an explosive atmosphere.

ATEX/IECEx Zone 2, Category 3G applications require the final installation location provide a IP-54 or higher ingress protection enclosure against dust and water per IEC 60529. The enclosure must meet IEC 60079-0 Design & Test Requirements.

Personnel must discharge their electrostatic build up to the cabinet ground point or use an ESD strap prior to touching the ProTech® SX interior surfaces if the engine/turbine is operational. The unit is designed to allow one of three modules be removed during operation. However, ESD to the remaining operational modules may cause signal deviations. Signal deviations due to direct ESD may be large enough to result in the operational modules tripping, shutting down the engine since two modules are in a tripped mode. Signal deviations were noted when ESD testing was done to the Speed pins, the IRIG-B pins, Service Port pins, and RS-232/RS-485 Modbus communications port pins.



Do not remove module unless module is de-energized and all wire connections have been disconnected



Do not remove covers or connect/disconnect electrical connectors unless power has been switched off and the area is known to be non-hazardous.

Explosion Hazard

The Service Port (RS-232 communication) is not designed to remain connected during operation except at servicing & programming intervals. It should not have a cable connected to it other than during programming & servicing.

This device contains a single cell primary battery. This battery is not to be charged and is not customer replaceable.

The Protech SX Control shall not be installed in areas exceeding Pollution Degree 2 as defined in IEC 60664-1.

The control must be mounted in a vertical position. The installer shall ensure the maximum surrounding air temperature of the control does not exceed +60°C at the final location.



MOUNTING

The control must be mounted in a vertical position. The installer shall ensure the maximum surrounding air temperature of the control does not exceed +60°C at the final location.

Explosion Hazard



Measurement inputs are classified as permanently connected IEC measurement Category I and are designed to safely withstand occasional transient overvoltages up to 1260 V(pk). To avoid the danger of electric shock, do not use these inputs to make measurements within measurement categories II, III, or IV.



Explosion Hazard—Do not connect or disconnect while circuit is live unless area is known to be non-hazardous.







Substitution of components may impair suitability for Class I, Division 2 or Zone 2 applications.

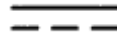

Risque d'explosion—Ne pas raccorder ni débrancher tant que l'installation est sous tension, sauf en cas l'ambiance est décidément non dangereuse.

La substitution de composants peut rendre ce matériel inacceptable pour les emplacements de Classe I, applications Division 2 ou Zone 2.

Safety Symbols

	Both direct and alternating current
	Alternating current
	Direct current
	Caution, risk of electrical shock
	Caution, refer to accompanying documents
	Protective conductor terminal
	Frame or chassis terminal

Chapter 1.

General Information

Description

The ProTech-SX ("ProTech Simplex") is a safety PLC (programmable logic controller) with integrated overspeed protection designed to safely shut down any plant process equipment, engine, or steam, gas, or hydro turbine upon sensing a safety event. This stand-alone safety system accepts two speed inputs and seven discrete/analog inputs, uses programmed logic to determine when a safety event has occurred, then issues system shutdown commands and alarms. The ProTech-SX uses five fast-acting, configurable relay outputs and an analog meter output to interface with the specific system or device being protected.

The ProTech-SX log function logs (saves to memory) all trips, alarms, trip valve response times, and overspeed events. The trip log function uses a scrolling buffer and records the last 50 sensed trip or alarm events and the last 20 overspeed events to memory, with associated times. Each log file can be viewed from the unit's front panel, or downloaded to a computer via the ProTech-SX service tool program. This safety PLC utilizes non-volatile memory to ensure all logged events are saved, even on loss of power.

The ProTech-SX provides various pre-defined and user-definable test features including automated periodic tests.

There are several ways to interface with the ProTech-SX. The front panel allows the user to view current values, and perform certain configuration and test functions. All of the features and most of the information available from the front panel is also accessible via the Modbus® * interface. Finally, the Programming and Configuration Tool (PCT) is software that is run on a PC to define configurable inputs and programmable logic, upload log files, and manage settings files.

*—Modbus is a trademark of Schneider Automation Inc.

This product is designed for critical applications and when installed correctly meets API-670, API-612, API-611, and IEC61508 (SIL-2) standards.

The following table shows the various hardware configurations (mounting options, power supplies, and trip relay options) available:

Table 1-1. Available ProTech-SX Models

Part Number	Description
8237-1242	ProTech-SX - Panel Mount, HV/LV
8237-1243	ProTech-SX - Panel Mount, HV/HV

Applications

The ProTech-SX is designed to be applied as a safety system for any size steam, gas, or hydro turbine, reciprocating engine, or plant process equipment. This safety PLC's fast (12 millisecond) response time, 0.5 to 32 000 rpm speed range, and integrated overspeed and acceleration detection/protection functionality, make it ideal for application on critical low-speed or high-speed rotating motors, compressors, turbines or engines. This standalone safety device accepts seven discrete or analog inputs and two speed inputs. It provides three programmable relay outputs and an analog speed output in addition to the trip relay outputs. Configurable logic allows the customization required to meet specific application requirements to ensure plant protection.

Alternatively, this standalone safety device can be configured to protect any plant system or device, and report the system's or device's status to the plant DCS. The ProTech-SX control's versatile inputs, outputs, programming environment, and communications make it ideal as a safety protection device for use in small applications that could possibly reach an unsafe state or condition and that must communicate directly to the plant DCS. The ProTech-SX is designed for critical applications where both personnel safety and unit availability (operation run time) is a concern or necessity.

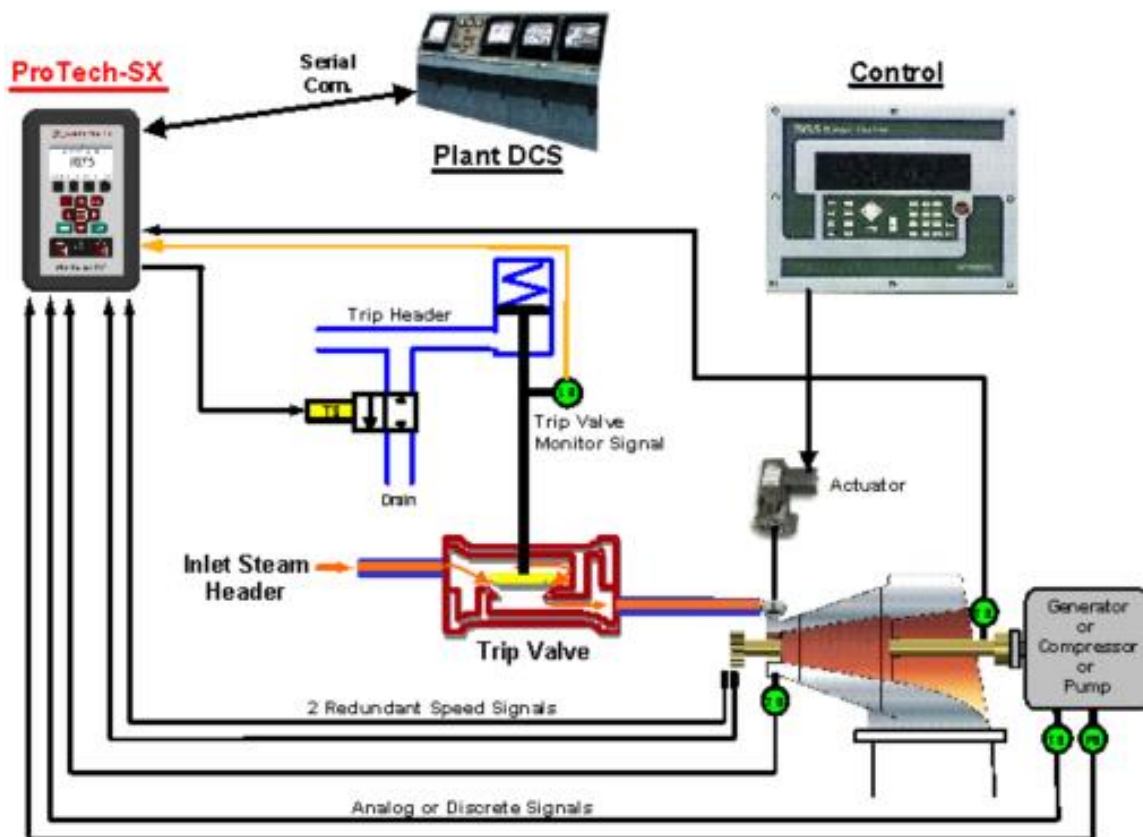

Figure 1-1. Typical ProTech-SX Application

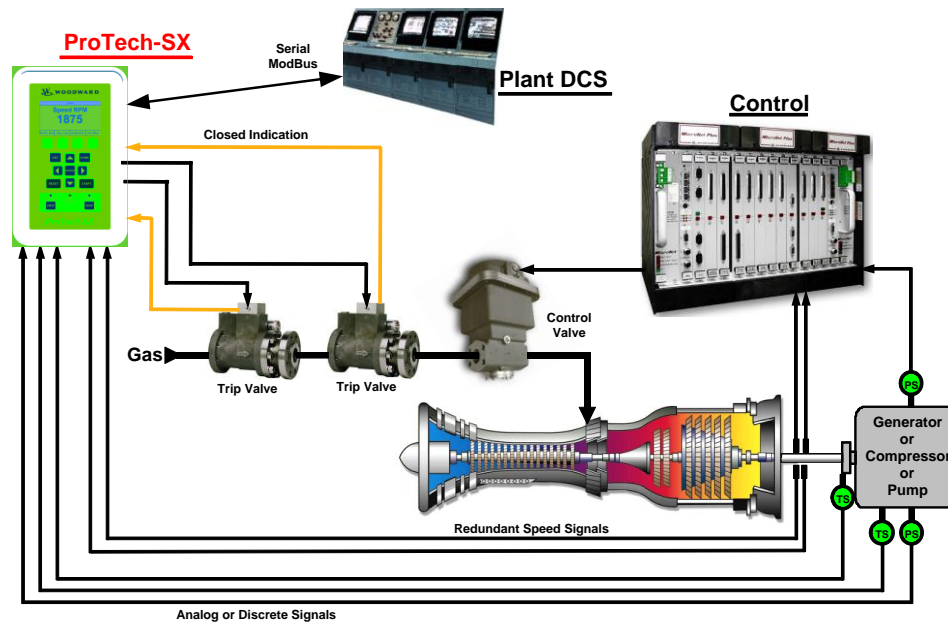

Figure 1-2. Typical Gas Turbine Application

AMMONIA REFRIGERATION VENT HEADER APPLICATION

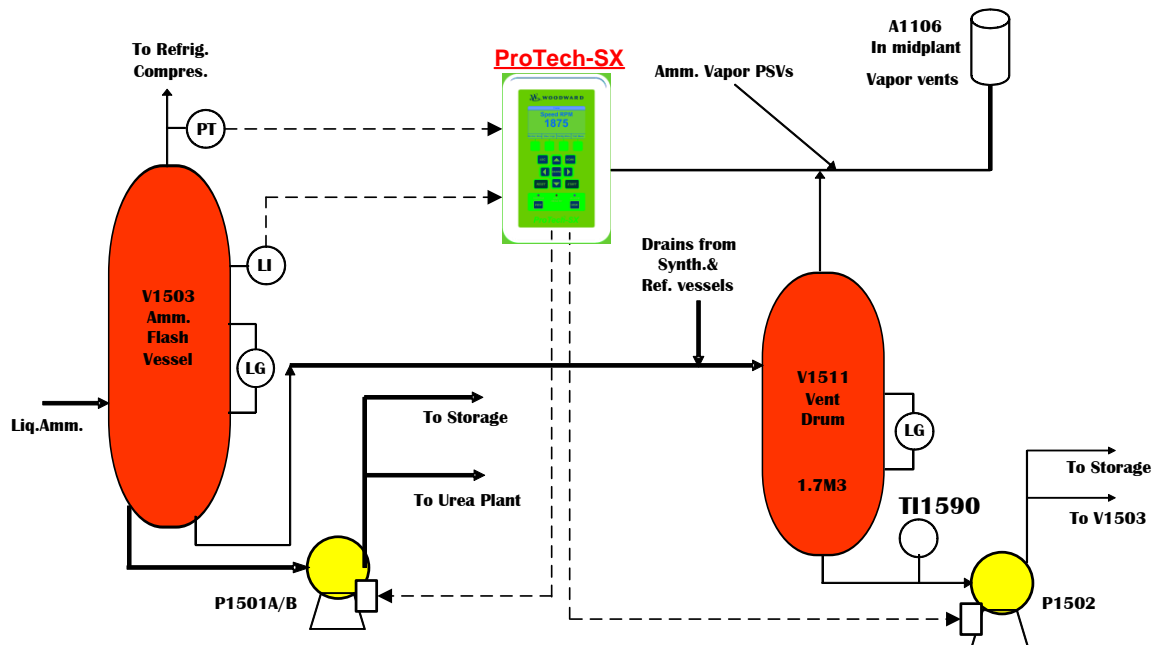

Figure 1-3. Typical Safety PLC Application

The ProTech-SX is certified as an IEC61508 SIL-2 (Safety Integrity Level 2) safety device and can be applied as a stand-alone IEC61508-based device or within an IEC61511-based plant safety system.

Chapter 2. Installation

Introduction

This chapter provides instructions on how to mount and connect the ProTech-SX into a system. Hardware dimensions, ratings, and jumper configurations are given to allow a customer to mount, wire, and configure the ProTech-SX package to a specific application.

Electrical ratings, wiring requirements, and options are provided to allow a customer to fully install the ProTech-SX into a new or existing application.

Unpacking

Before opening the shipping packaging, inspect the shipping container for damage and document any damage.

Be careful when opening and removing the shipping container. You may retain the original shipping container for unit storage or for return shipping when suggested refurbishment is required. (See Asset Management chapter for storage details.)

Be careful when unpacking the ProTech-SX system from the shipping container. The precautions called out in the Electrostatic Discharge Awareness section should be followed during unpacking, handling, installation and operation during maintenance.

Once removed from the shipping packaging, check the device for signs of damage such as a bent or dented case and loose or broken parts. If damage is found, notify the shipper immediately.

System Installation Procedure

1. Review the system manual to gain a complete understanding of the ProTech-SX system.
2. Create a site specific wiring diagram by referencing included wiring diagrams & constraints, then perform mechanical and electrical installation following this chapter's instructions.
3. Visual inspection
 - a. Verify that all mounting hardware is tightened and that no wires are pinched.
 - b. Verify that no wiring insulation is nicked or abraded.
 - c. Verify that all terminal blocks are installed and terminal screws are tight. (Follow the control wiring instructions for all terminal blocks.)
 - d. If used, verify that speed sensors have been correctly installed, and have the correct clearance from the speed gear (adjust if necessary). See manual 82510, Magnetic Pickups and Proximity Switches for Electronic Governors.
4. Apply power to the module, and verify that the module boots up and that its front panel screen displays turbine speed.
5. If no special programming logic is used skip to step 8.
6. If special programming logic is required install the ProTech-SX Programming and Configuration tool (PCT) from provided PCT Installation CD on to the desired computer and create the system application program
7. Once the system application program is complete, connect an extension (i.e. straight-through, not null-modem) RS-232 serial cable from the respective computer to the module's service port, and download the program into the module
8. From the module's front panel, enter the configuration mode and verify that each of the overspeed and over-acceleration settings is correct.
9. Perform a full system checkout by verifying that all system trips, alarms, and test routines function correctly before starting the machinery/system.
10. When ready, start the turbine/machinery following the equipment manufacturer's recommended starting procedure

Enclosures

The ProTech-SX panel-mounted enclosure model is designed for installation within a control room panel or cabinet, and by itself cannot be bulkhead mounted. Once installed within an IP56 rated panel or cabinet, the ProTech-SX is rated for IP56-based environments. A gasket is attached to the rear side of the package's bezel to properly seal the ProTech-SX control's face-plate and around the mounting studs to a panel. Field wiring access is located on the control's back side. Figures 2-1 and 2-2 display the Panel-Mount ProTech-SX model's layout and mounting pattern.



Figure 2-1a. Typical ProTech-SX Panel Mount Package—Front View

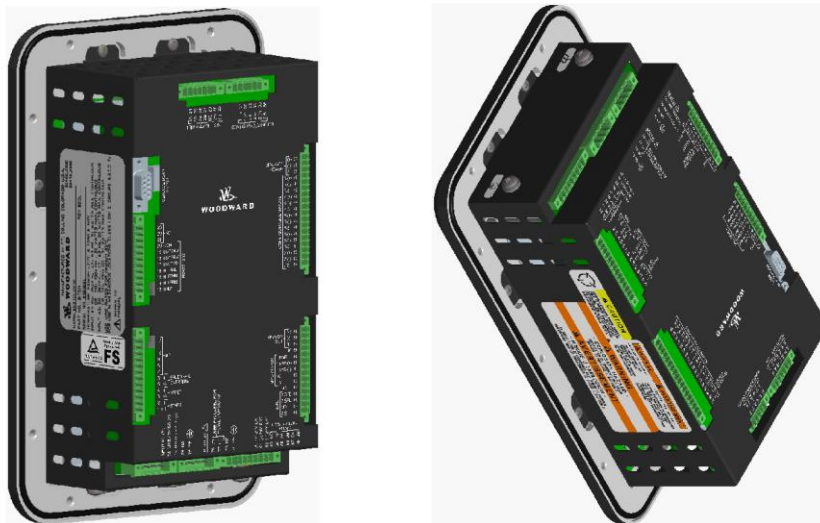

Figure 2-1b. Typical ProTech-SX Panel Mount Package—Rear View with Cover

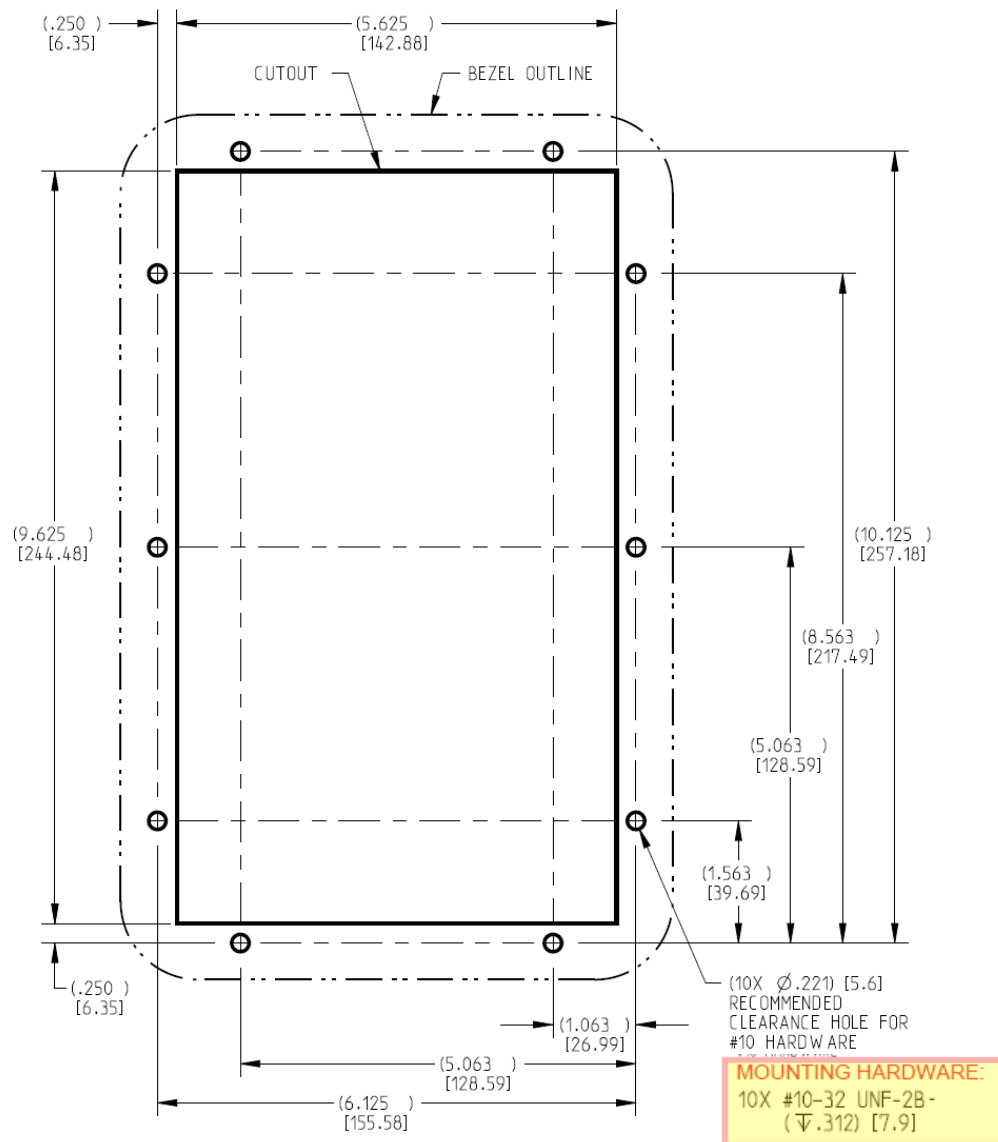

Figure 2-2a. Mounting Outline Diagram for ProTech-SX Panel-Mount Models

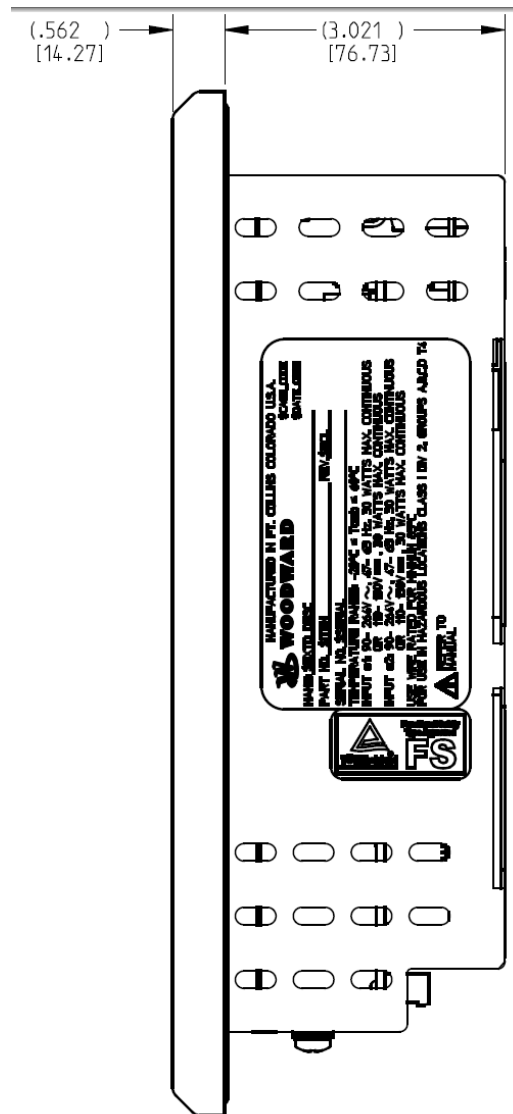

Figure 2-2b. Mounting Outline Diagram for ProTech-SX Panel-Mount Models

Mounting Location Considerations

Consider the following general requirements when selecting the mounting location:

- Adequate ventilation for cooling
- A location that will provide an operating temperature range of -20 to $+60$ °C (-4 to $+140$ °F)
- The ProTech-SX weighs approximately 2.2 kg (4.9 lb)
- Space for opening & servicing
- Space for installing & removing panel mount covers
- Space for installing cable strain relief as needed
- Vertical orientation of the unit
- Protection from direct exposure to sunlight, water, or to condensation-prone environments
- Protection from high-voltage or high-current devices which produce electromagnetic interference
- Avoidance of vibration
- A location that has H_2S and SO_2 gases at or below the levels classified in international standard IEC 721-3-3 1994 - environment Class 3C2
- Maximum purge pressure: 4 psi

Environmental Specifications

Table 2-1. Environmental Specifications

Operating Temperature	-20 to +60 °C
Storage Temperature (Non-operational)	-20 to +65 °C
Relative Humidity	up to 95% non-condensing
Vibration	2 hrs/axis, 0.04 G ² /Hz, 1.04 Grms, 10–500 Hz, three axis
Shock:	±3 pulses, 30 G, 11 ms half sine shock, three axis
IP Rating	56
Altitude	up to 3000 meters above sea level
Electromagnetic Compatibility	Emissions: EN61000-6-4 Immunity: EN61000-6-2
Overvoltage Category	II (per IEC 60664-1)
Pollution Degree	2 (per IEC 60664-1)
Weight:	Approximately 2.2 kg (4.9 lb)

Power Supply Requirements

Depending on the ProTech-SX model purchased, the module will accept either two high voltage (HV) input power sources or one HV input power source and one low voltage (LV) input power source.

Table 2-2. Power Supply Specifications

Number of Inputs	2, input range depends on model (see following tables): <ul style="list-style-type: none"> • 2 high voltage inputs OR • 1 high voltage and 1 low voltage
Wiring Constraints	Each power supply input must be provided with its own breaker. This is to facilitate both on-line-removal of a module, as well as to protect other power supplies from tripping while connected to a common input power circuit.

Table 2-3. High Voltage Input Specifications

Voltage Input Range	90 – 264 VAC/47–63 Hz, or 100 – 150 VDC @ 30 W With Nominal 115 VAC / 240 VAC / 125 VDC
Current Input Max (Note 1)	0.5 A @ 90 VAC 0.22 A @ 264 VAC 0.25 A rms @ 110 VDC 0.18 A rms @ 150 VDC
Inrush Current	10 A at 115 VAC, 20 A @ 220 VAC
Reverse Polarity Protection	Yes, for dc connection
Interrupt Time	45 ms, when operating on one power supply only

Table 2-4. Low Voltage Input Specifications

Voltage Input Range	18 – 32 VDC @ 30 W with Nominal 24 VDC
Current Input Max (Note 1)	1.5 A @ 18 VDC 1 A @ 32 VDC
Inrush Current	0.05 A ² sec
Reverse Polarity Protection	Yes
Interrupt Time	3 ms, when operating on one power supply only

Note 1: The input current specifications are for one module, measured with the other power supply input disconnected. With both power supply inputs connected, input current will never exceed the maximum specification, however the two power supplies do not load-share internally.

The ProTech-SX module will function normally with power sourced to both or either power supply input independently; however, Woodward recommends that both input power sources be used to improve system availability. Please refer to Table 1-1 for available ProTech-SX models.

IMPORTANT

Since the ProTech-SX is designed to detect a failure of either power supply input, a continuous “Power Supply Fault Alarm” will be issued if power-sources are not connected for both power supply inputs.

Internally Generated Limited Power Supplies

Table 2-5. Signal Input Power Supply Specifications

Output Voltage	24 VDC \pm 10%
Current Limit	50 mA

IMPORTANT

Avoid using the Configurable Input Power Supply to power any analog input channels. It is intended for use with inputs that are configured for discrete mode only.

Table 2-6. Relay Output Power Supply Specifications

Output Voltage	24 VDC \pm 10%
Current Limit	500 mA

Each ProTech-SX module requires a power source capable of a certain output voltage and current. In most cases, this power rating is stated in Volt-Amps (VA). The maximum VA of a source can be calculated by taking the rated output voltage times the maximum output current at that voltage. This value should be greater than or equal to the VA requirement listed.

WARNING

Each power source must be provided with an external disconnecting means that is identifiable to the specific power supply.

NOTICE

A PE (Protective Earth) ground wire for each of the high voltage power supplies must be connected to PE ground. The PE ground connection wire must originate and be connected to PE at the power source. The PE ground wire must follow the power wires to the applicable power input connector PE Ground pin, so that each HV input has a PE ground. The PE ground wire gauge must be capable of handling the same current as the individual power wiring.

NOTICE

A PE (Protective Earth) ground wire for the enclosure must be provided and connected to PE Ground. At least one of the enclosure’s PE labeled connection points must have a wire going from the enclosure to a building PE ground point. This wire must be of sufficient gauge to handle the rated current of all the interposing relay wires or 1.5 mm² (16 AWG), whichever is larger.

Input/Output Signal Specifications

Speed Input Specifications

Table 2-7. General Input Specifications

Number of Inputs	2 Input channels
	Speed Input 1 is selectable as passive or active probe by front panel configuration
	Speed Input 2 is MPU only
Speed Sensing Accuracy	Accuracy: $\pm 0.04\%$ of current speed over -20 to $+60$ °C ambient temperature
Acceleration Sensing Accuracy and Range	Accuracy: $\pm 1\%$ of current speed Detectable over-acceleration range: 0 to 25000 rpm/s
Signal Cable Length	Must be limited to 1500 ft /457 m (low capacitance 16 AWG / 1.3 mm ²)
Internal Test Frequency Generator (Speed input 1 only)	6 Hz to 32 kHz, selectable in different test modes, see Chapter 4, Configuration and Operation
Open Wire Detection	Speed Inputs 1 and 2

Table 2-8. Passive Speed Probe Specifications

Input Frequency	Passive Probe (MPU): 100 Hz to 32 kHz
Input Amplitude	1 Vrms to 35 Vrms
Input Impedance	1.5 k Ω
Isolation	500 VAC from input to chassis and input to all other circuits
Open Wire Detection	MPU only > 7.5 k Ω
Amplitude Modulation	Input is capable of handling up to 20% amplitude modulation at 60 Hz as long as the minimum signal requirements are met.

Table 2-9. Active Speed Probe Specifications

Input Frequency	Active Probe (Proximity, Eddy Current): 0.5 Hz to 25 kHz
Input Amplitude	Active Probe: 24 V probes
Probe Power	24 V $\pm 10\%$ @ 1 W, probe power switched on only in active probe mode.
Internal Pull-up Resistor	10 k Ω , input suitable for use with open collector probe outputs (Note 1)
Input Threshold (Vlow)	< 2 V
Input Threshold (Vhigh)	> 4 V
Isolation	500 VAC from input to chassis and input to all other circuits

IMPORTANT

Each speed input is designed to operate from its own speed probe. Do not connect a speed probe to more than one input. This will compromise the ability of the ProTech-SX to sense open wire (passive mode only) and interfere with the minimum amplitude sensitivity and accuracy.

IMPORTANT

When using open collector probes, verify that the signal is being read properly at higher frequencies (>10 kHz). Long cable lengths can significantly reduce the signal strength at higher frequencies. In this case, add an external pull-up resistor of approximately 2 k Ω (0.25 W) from terminals 70 to 69 and verify that the signal is read properly by the ProTech-SX.

IMPORTANT

Shielded cable is required when connecting to the speed input.

Table 2-10. Dedicated Discrete Input Specifications

Number of Channels	3, (Start, Reset, Speed Fail Override)
Input Thresholds	≤ 8 VDC = "OFF" ≥ 16 VDC = "ON"
Input Current	3 mA $\pm 5\%$ at 24 V (for externally power wiring, see, Chapter 2)
Wetting Current Supply	24 V at 2 W available (see installation diagrams, Chapter 2). This power supply is current limited.
Max Input Voltage	32 V (for externally power wiring, see, Chapter 2)
Isolation	500 VAC from output to chassis and output to all other circuits

Configurable Input Specifications

Table 2-11. General Input Specifications

Number of Channels	7, user-configurable for individual analog or discrete input mode
Signal Cable Length	Must be limited to 1000 ft / 305 m (low capacitance 16 AWG / 1.3 mm ²)

Table 2-12. Analog Input Specifications

Input Current Range	0 to 25 mA
Common Mode Rejection	45 dB at 60 Hz
Input Common Mode Range	± 40 V
Input Impedance	200 Ω $\pm 1\%$
Resolution	12 bit
Accuracy	$\pm 0.25\%$ of 25 mA at 25 °C, (<i>note 1</i>) $\pm 0.5\%$ of 25 mA over-temperature
Analog Input Fail Thresholds	Fixed at 2 mA and 22 mA
Isolation	500 VAC from input to chassis and input to all other circuits, not galvanically isolated to other channels in analog mode. Faults or signals on one channel will not affect other channels.
Anti-aliasing Filter	2 poles at 500 Hz

- Loop power is not provided by the ProTech-SX
 - Shielded twisted pair cable is required when connecting to the analog inputs.
- Note 1: $\pm 0.25\%$ represents the pk-pk noise of the input. The average accuracy is $\pm 0.1\%$ of 25 mA.

Table 2-13. Discrete Input Specifications

Input Thresholds	≤ 6 VDC = "OFF" ≥ 12 VDC = "ON"
Input Current	5 mA $\pm 5\%$ at 24 V (5 k Ω input impedance)
Wetting Current Supply	24 V at 2 W available (see installation diagrams, Chapter 2). This power supply is current limited.
Max Input Voltage	32 V
Isolation	500 VAC from input to chassis. In discrete mode, the discrete input shares a common internal ground with the other channels that are in discrete mode.

Table 2-14. Trip Relay Output Specifications

Number of Channels	2 (actuated simultaneously)
Output Type	SPST Solid-state, Normally Open
Current Rating	1 A
Voltage Rating	24 V (32 V max)
Isolation	500 VAC from output to chassis and output to all other circuits
Signal Cable Length	Must be limited to 1000 ft / 305 m (low capacitance 16 AWG / 1.3 mm ² pair)

Table 2-15. Programmable Relay Output Specifications

Number of Channels	3
Output Type	SPST Solid-state, Normally Open
Current Rating	1 A
Voltage Rating	24 V (32 V max)
Isolation	500 VAC from output to chassis and output to all other circuits
Signal Cable Length	Must be limited to 1000 ft / 305 m (low capacitance 16 AWG / 1.3 mm ²)

Table 2-16. Analog Output Specifications

Number of Channels	1
Output Type	4–20 mA, isolated
Max Current Output	25 mA
Accuracy	$\pm 0.1\%$ at 25 °C, $\pm 0.5\%$ over temperature
Resolution	12 bit
Response Time	< 2 ms (2 to 20 mA)
Min Current Output	0 mA
Min Resistive	0 Ω
Max Resistive Load	500 Ω at 25 mA
Isolation	500 VAC from output to chassis and output to all other circuits
Signal Cable Length	Must be limited to 1000 ft / 305 m (low capacitance 16 AWG / 1.3 mm ²)

Shielded twisted pair cable is required when connecting to the analog outputs.

Serial Communication Port (RS-232/RS-485) Specifications

Table 2-17. Serial Communications Port Specifications

Number of Ports	1
Comm Type	RS-232/RS-485, user selectable
Termination Resistor	RS-485 on board, terminal block selectable
Isolation	500 VAC from output to chassis and output to all other circuits
Signal Cable Length	Must be limited to 1500 ft / 305 m (low capacitance 16 AWG / 1.3 mm ²)

Shielded Wiring

All shielded cable must be twisted conductor pairs with either a foil or a braided shield. A braided shield is preferred and highly recommended. All analog & communication signal lines should be shielded to prevent picking up stray signals from adjacent equipment. Connect the shields as shown in the control wiring diagram (Figure 2-4). Wire exposed beyond the shield must not exceed 50 mm (2 inches). The shield termination should be done with the shield by opening the braid and pulling the wires through, not with an added wire. If a wire is used it must be the largest gauge accepted by the shield lug terminal. The other end of the shield must be left open or grounded through a capacitor and insulated from any other conductor. Do not run shielded signal wires with other wires carrying large currents or high voltages. See Woodward manual 50532, *EMI Control in Electronic Governing Systems*, for more information.

Installations with severe electromagnetic interference (EMI) may require relay and discrete input wiring to be shielded. Conduits and/or double shielded wire may be needed, or other precautions may have to be taken. These additional precautions may be implemented in any installation. Contact Woodward for more information.

Control Wiring Guidelines

Electrical Connections

 WARNING	EXPLOSION HAZARD—Do not connect or disconnect while circuit is live unless area is known to be non-hazardous.
--	--

Figure 2-4 shows the control wiring diagrams for the ProTech-SX system. Refer to Figure 2-4 for proper routing and stress relief of field wiring entering the ProTech-SX system. Wire tie-wrap fasteners are provided on each module to assist with I/O wire routing and installation.

Plug-in screw-type terminal blocks are used to connect field wiring to the ProTech-SX module and to the trip (interposing) relay contacts.

The size of the field wiring to the ProTech system should be between 1.5 and 6 mm² (16 and 10 AWG) for power supply wiring and between 0.3 and 4 mm² (22 and 12 AWG) for all other I/O wiring. Wires for all the pluggable I/O terminal blocks should be stripped at 8 mm (0.3 inch). Torque and screwdriver requirements are listed below.

IMPORTANT	<p>The screw lug terminal blocks are designed to flatten stranded wire. Do not tin (solder) the wire's strands that terminate at the ProTech Terminal Blocks. If the wire strands are soldered together, the solder will cold flow and shrink over time causing the connection to become intermittent or disconnected.</p> <p>Woodward recommends the following for ProTech-SX:</p> <ul style="list-style-type: none"> • Stranded bare copper wire at the wire ends (unless gaseous Sulfur compounds are present). • Stranded copper wire with individually tin plated strands at the wire ends. • Hollow ferrules at the wire ends. • Use a single wire per terminal. There are enough terminals provided for all I/O wiring.
------------------	--

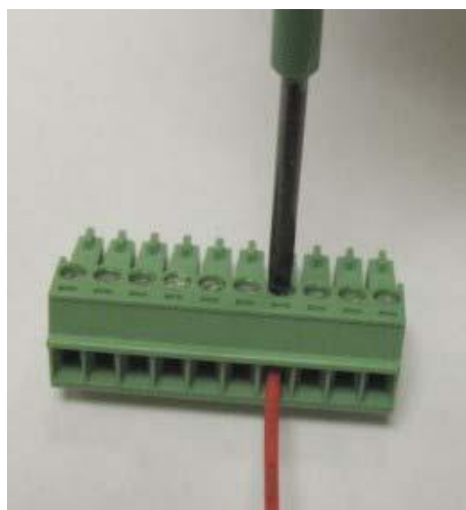

Torque range for screws of Screw Connection Terminal Blocks:
0.22–0.25 N•m (1.95–2.21 lb-in).

Screwdriver blade:
0.4 X 2.5 mm (0.016 X 0.10 inch)
Screwdriver available as
Woodward PN 8992-005

Figure 2-3. Screw Connection Terminal Block

The ProTech-SX control's terminal blocks are designed to be removed by hand.

With circuit power and trip (interposing) relay-controlled power disconnected, all terminal blocks can be removed, one at a time, by unscrewing their terminal-locking screws and pulling them out of their sockets by hand.

NOTICE

When removing a terminal block, never pull on the wires connected to the terminal block.

Field wiring access is located on the back of the ProTech-SX enclosure. Refer to Figure 2-4 for field wiring access information. For EMI (electromagnetic interference) reasons, Woodward recommends that all low-voltage field wiring be separated from all high-voltage field wiring where possible. Woodward also recommends that power wiring be segregated in the same manner. However, LV & HV input power may be routed together.

WARNING

HIGH VOLTAGE—When wiring to interposing relays, be sure to wire both contacts with the same polarity. Failure to do so will create a potential shock hazard, which could cause injury or death.

IMPORTANT

All input and output wiring must be in accordance with Class I Division 2 wiring methods, and in accordance with the authority having jurisdiction.

All peripheral equipment must be suitable for the location in which it is being used.

Speed Sensor Inputs

The ProTech-SX senses speed and acceleration via one or two speed signal inputs. Speed input #1 can be configured to accept signals from passive, active, or eddy-current speed probes. Speed input #2 is optional and accepts a signal from a passive speed probe only. As both speed signal inputs utilize the same “Number of Gear Teeth” and “Gear Ratio” configuration settings, it is recommended that both speed probes be mounted to sense speed from the same gear connected to the turbine/motor rotor or engine crank shaft.

Speed sensors for speed input number 1 may be any of the following:

- Passive magnetic pickup unit (MPU)
- Active proximity probe
- Eddy current probe

Speed sensors for speed input number 2 may be any of the following:

- Passive magnetic pickup unit (MPU)

A passive MPU provides a frequency output signal corresponding to turbine speed by sensing the movement of a gear's teeth past the MPU's pole piece. The closer the MPU's pole piece is to a gear's teeth and the faster the gear turns the higher a passive MPU's output amplitude will be (speed signal amplitude increase with both speed increase and distance decrease). The ProTech-SX must sense an MPU voltage of 1 to 35 Vrms for proper operation. With proper MPU, gear size, and MPU-to-gear clearance, speed measurement can range from 100 to 32 000 Hz. Standard MPU clearance is recommended to be 0.25 to 1.02 mm (0.010 to 0.040 inch) from tooth face to pole piece. For information on selecting the correct MPU or gear size please refer to Woodward manual 82510. Refer to Figure 2-5a for wiring information.

Proximity and eddy-current probes may be used to sense very low speeds to high speeds (0.5 to 25 000 Hz). The speed probe input voltage must be between 16 and 28 VDC, and output signal must meet high and low threshold values in Table 2-9 for proper speed detection. The voltage for the speed probes must be from the provided voltage port or have its common referenced (connected) to the provided common pin for proper operation. See Figures 2-5c and d for proximity and eddy-current probe wiring schematics.

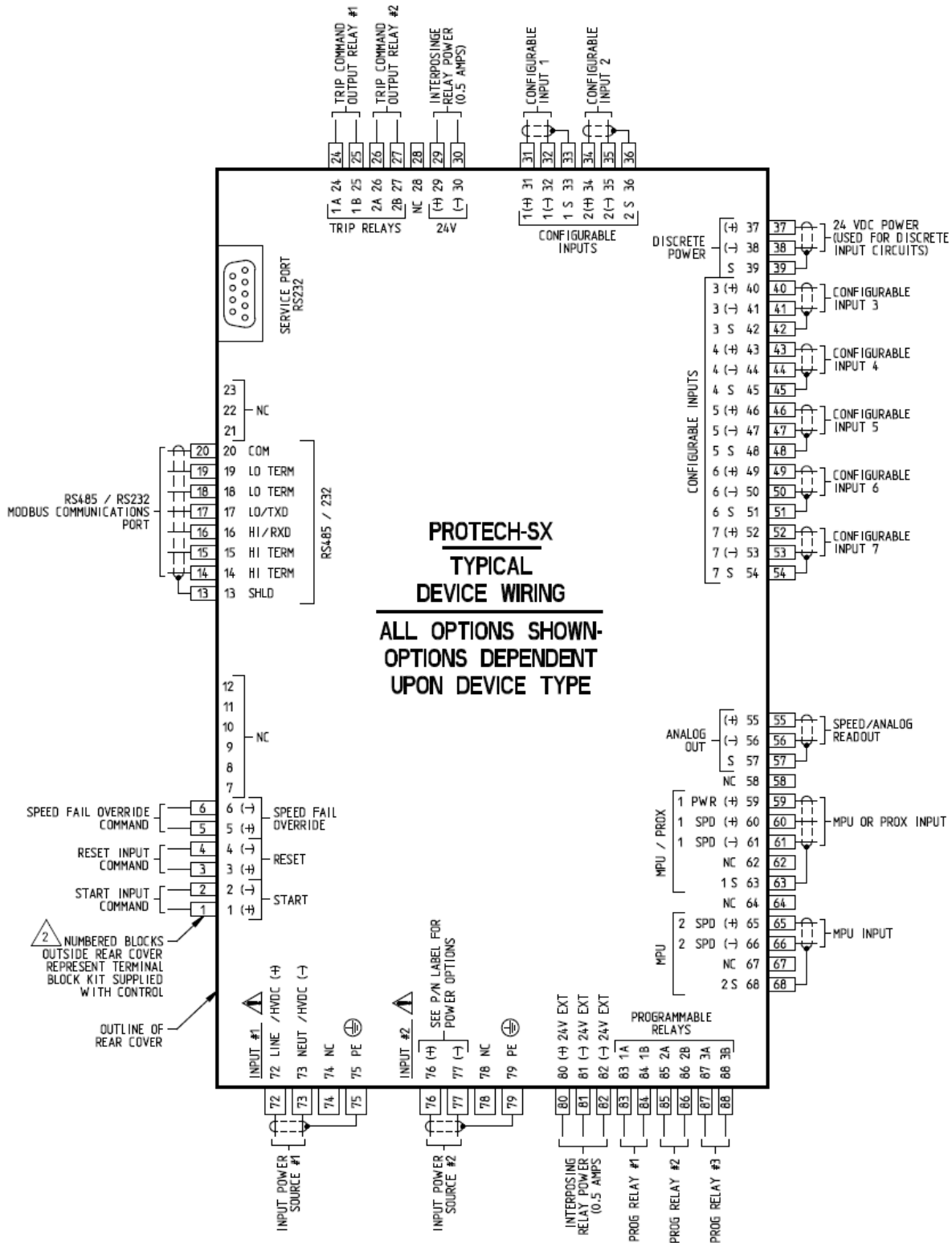

Figure 2-4. ProTech-SX Control Wiring Diagram

An application may use the same or different types of speed probes (MPU, proximity, eddy-current), connected to the two speed inputs depending on the specific application's requirements.

IMPORTANT

Woodward does **NOT** recommend that gears mounted on an auxiliary shaft that is coupled to the turbine rotor be used to sense turbine speed. Auxiliary shafts tend to turn slower than the turbine rotor (reducing speed-sensing resolution) and have coupling gear backlash, resulting in less than optimal speed sensing. For safety purposes, Woodward also does **NOT** recommend that the speed sensing device sense speed from a gear coupled to a generator or the mechanical drive side of a system's rotor coupling.

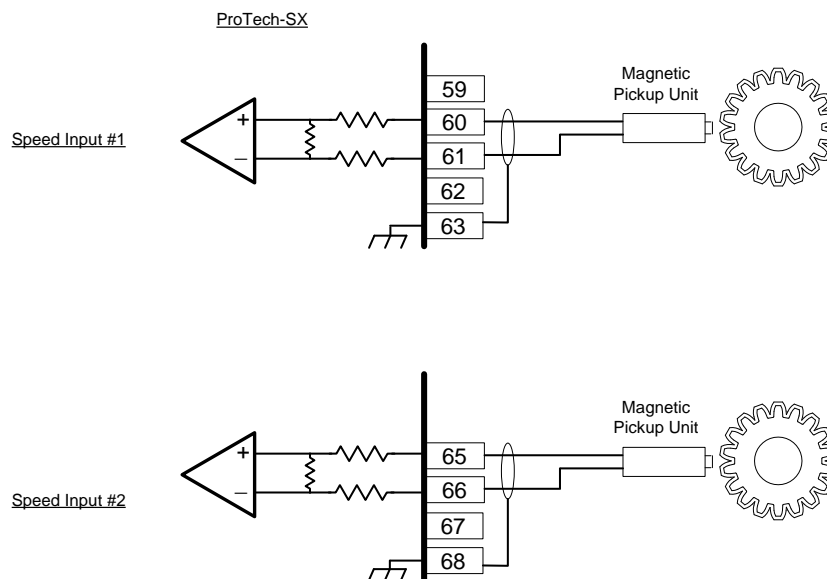

Figure 2-5a. Example MPU (Passive Magnetic Pickup Unit) Wiring

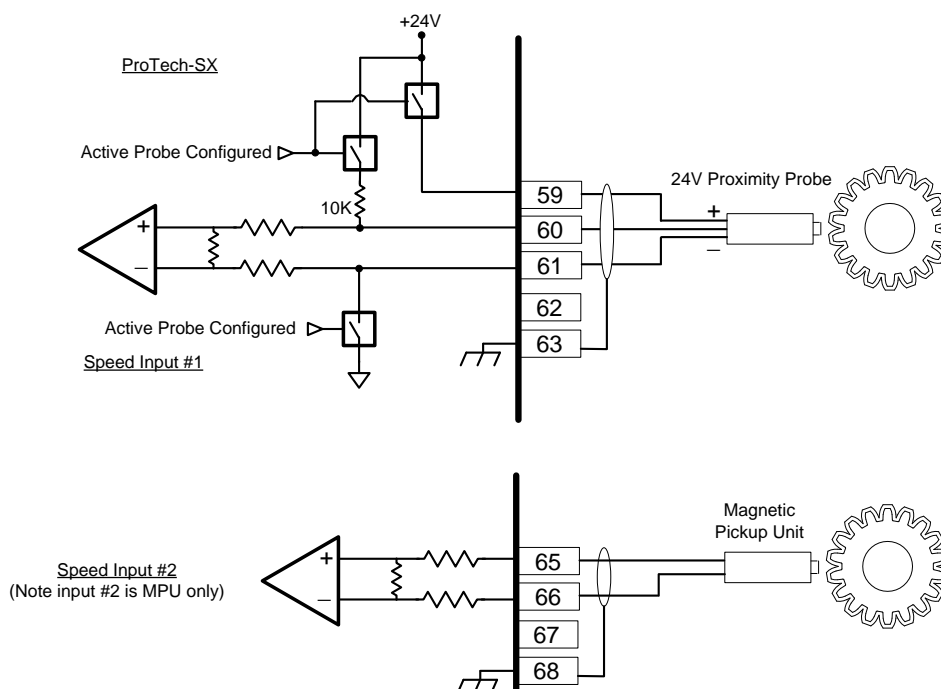

Figure 2-5b. Example Proximity Probe (Active Magnetic Pickup Unit) Wiring (Internal Power)

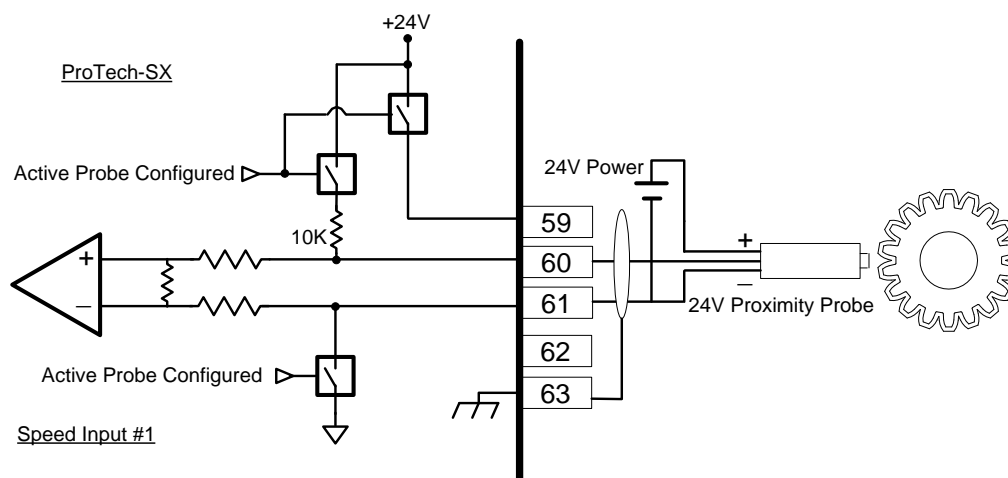

Figure 2-5c. Example Proximity Probe (Active Magnetic Pickup Unit) Wiring (External Power, Non-preferred)

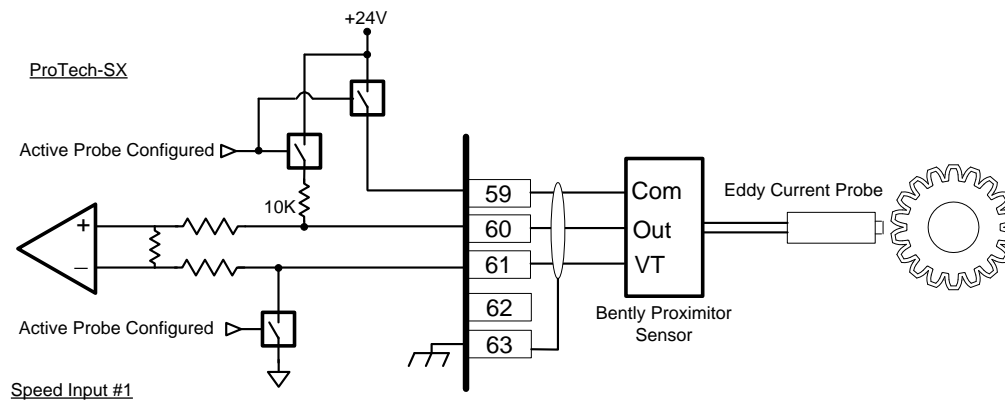

Figure 2-5d. Example Eddy Current Probe (Active Magnetic Pickup Unit) Wiring

Dedicated Discrete Inputs

The ProTech-SX module accepts three dedicated discrete inputs. All discrete inputs accept dry contacts. Contact wetting voltage is available through terminals 1, 3, and 5 but an external +24 VDC source can be used. Refer to Figure 2-6 for wiring information. In general, an input contact signal must change state for a minimum of 10 milliseconds for a ProTech-SX module to sense and register a change in state. The Dedicated Discrete Inputs are Start, Reset and Speed-Fail-Override. Refer to Chapter 3 (Functionality) of this manual for information on each discrete input's functionality.

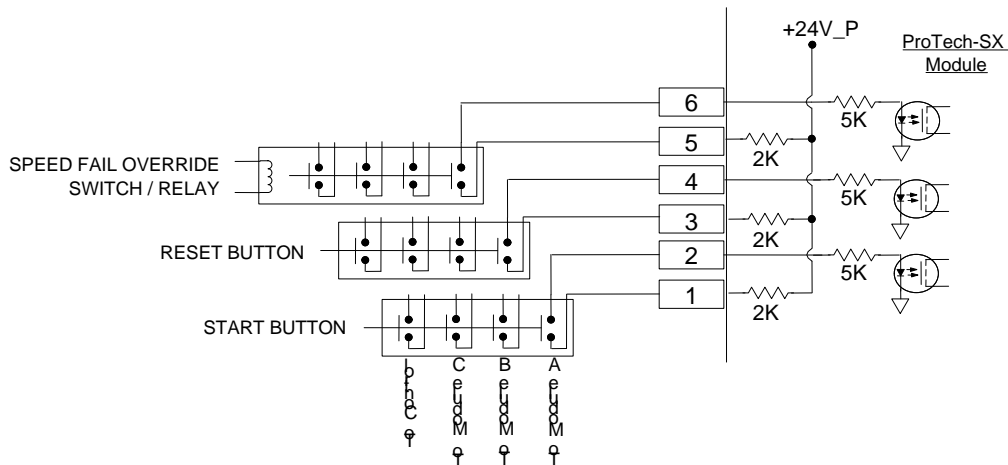

Figure 2-6a. Example Standard Discrete Input Wiring (Internal Power Option)

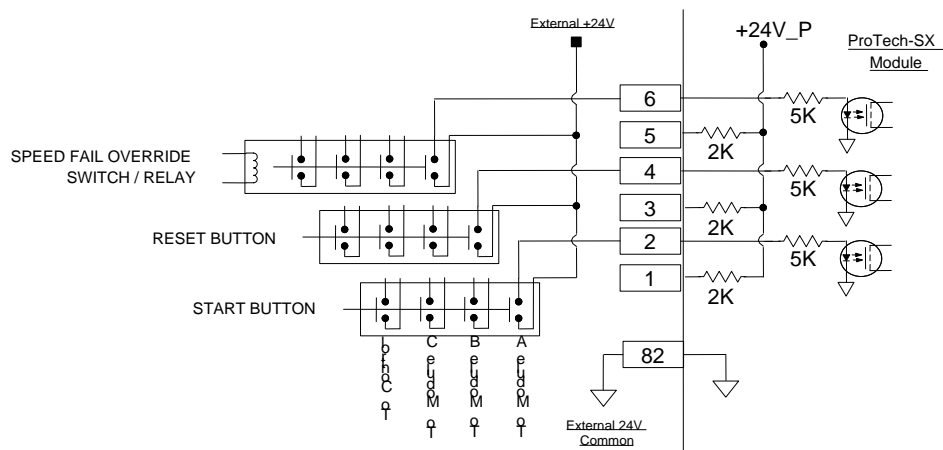

Figure 2-6b. Example Standard Discrete Input Wiring (External Power Option)

Configurable Discrete and Analog Inputs

Seven configurable inputs are available to sense discrete contact input signals or 4–20 mA analog input signals. Depending on the application's needs, each input can be configured within the ProTech-SX Programming and Configuration Tool (PCT) to function as discrete or analog input.

Configurable Discrete and Analog Inputs—Discrete Input Wiring

When an input is configured to function as a discrete input, it must be wired as shown in Figures 2-7a or b to function properly. Contact wetting voltage is available through terminal 37. Discrete input wires do not need to be shielded, but may be shielded. If shielding is used, terminate shield as indicated on AI mode. If a shield is used, a common wire must be run with the signal wire for field powered DI's, and both power & common must run with the signal wire for ProTech-SX powered DI's. Shielded DI's may be grouped with multiple signals & one common/power wire in a single shield. In general, an input contact signal must change state for a minimum of 4 milliseconds for a ProTech-SX module to sense and register a change in state. Refer to Chapter 3 (Functionality) of this manual for information on how to program and use each discrete input in an application.

NOTICE

If total current drawn through terminal 37 exceeds 50 mA, the power supply's internal breaker will open. Upon such a condition, all load must be removed from the specified terminals to allow this breaker to reset. The internal 24 V provides enough power to operate all 10 inputs in discrete mode.

NOTICE

For reliability reasons, Woodward recommends that input circuitry for a ProTech-SX module be fully isolated from the input circuitry of any other ProTech-SX module (if applicable). For example, the power source and wiring for the first ProTech-SX module should not be shared or connected in any way to a second ProTech-SX module.

If desired, an external 18–26 VDC power source can be used for the circuit-wetting voltage. In this case, terminal 38 (contact input common) must be connected to the external power source's common to establish a common reference point. Each contact input pulls 4.8 mA at 24 V when closed and requires at least 2.5 mA and 14 V to recognize a closure command. Refer to Figure 2-7b for wiring information.

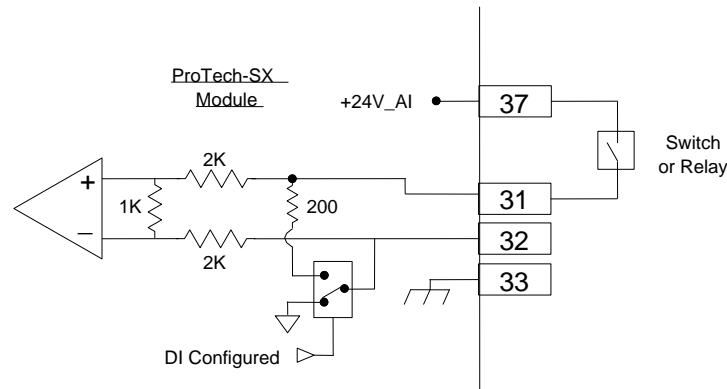

Figure 2-7a. Example Configurable Input Wiring—Discrete Input (Internal Power Option)

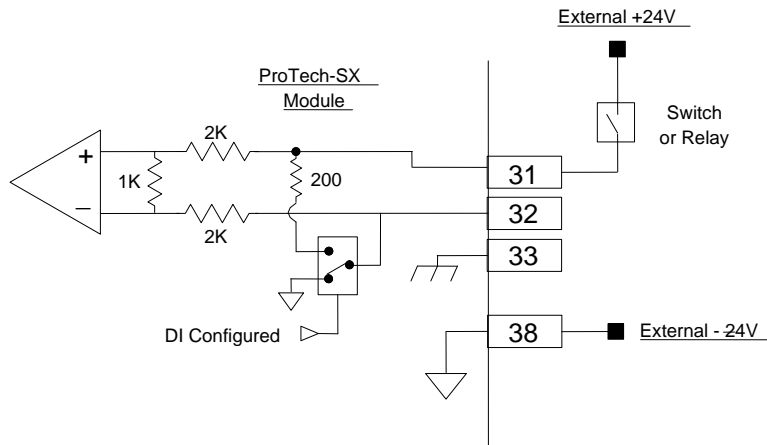

Figure 2-7b. Example Configurable Input Wiring—Discrete Input (External Power Option)

Configurable Discrete and Analog Inputs—Analog Input Wiring

When a configurable input is programmed to function as an analog input, it accepts a two-wire, ungrounded, loop-powered signal, and must be wired as shown in Figure 2-8 to function properly. The input impedance of the analog input circuit, as indicated in Figure 2-8, is 200 Ω . When configured as an AI, twisted shielded pair wiring must be used. Refer to Chapter 3 (Functionality) of this manual for information on how to program and use each analog input in an application. Refer to the Chapter 3 (Functionality) of this manual for applicable analog input specifications.

Because analog inputs are not fully isolated, take care in their application and maintenance to avoid “ground-loop” type problems. If interfacing to a non-isolated device with one of these inputs, the use of a loop isolator is recommended to break any return current paths, which could result in erroneous readings. Also, if a loop isolator is not used and the non-isolated field device has a signal (or power) reference to PE ground connection, damage may occur during PE ground bounce or high current transient ground fault conditions due to large potential differences in the remote PE ground and the local PE ground.

NOTICE

For reliability reasons, Woodward recommends that input circuitry for each ProTech-SX module be fully isolated from the input circuitry of any other ProTech-SX module. For example, the power source and wiring for the first ProTech-SX module should not be shared or connected in any way to another ProTech-SX module.

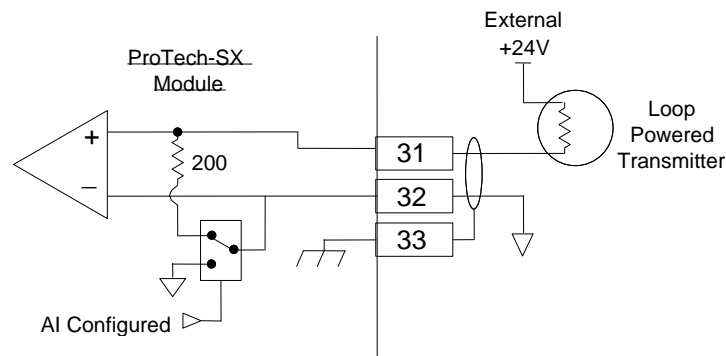

Figure 2-8. Example Configurable Input Wiring—Analog Input

Analog Output

One programmable 4–20 mA analog output is available to drive a readout meter or interface with other controllers or plant DCS's (distributed control systems). This output is designed to drive into an impedance between 0 to 500 Ω . Twisted shielded pair wiring must be used. Refer to Chapter 3 (Functionality) of this manual for applicable analog output specifications. Refer to Chapter 3 (Functionality) of this manual for information on how to program and use this analog output in an application.

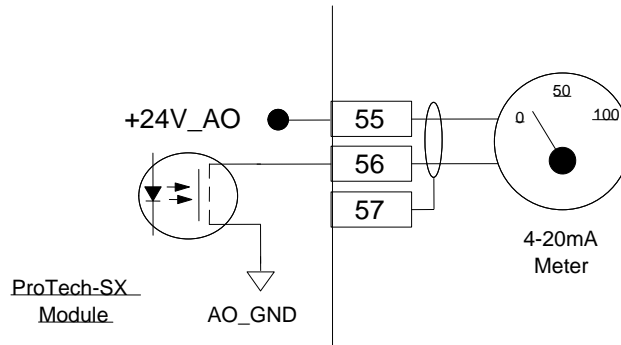

Figure 2-9. Example Analog Output Wiring

Relay Outputs

Refer to the Chapter 3 (Functionality) of this manual for all applicable relay output specifications. Refer to Chapter 3 (Functionality) of this manual for information on how to configure and use each programmable relay output in an application.

Trip Relay Outputs

Each ProTech-SX has five solid-state relay outputs. Each of the five solid-state relays have normally-open type contacts and are rated for 24 VDC @ 1 A. Two of these relay outputs are dedicated as redundant trip signal outputs, and the other three relay outputs are user-programmable which can be programmed to function independently as required. Refer to Figure 2-10a for relay terminal location and Figure 2-10b for wiring information.

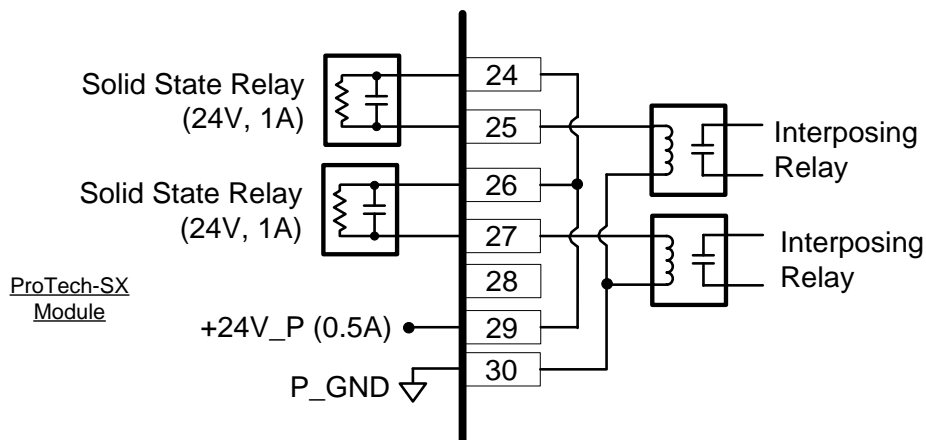

Figure 2-10a. Example Trip Relay Wiring (Internal Supply)

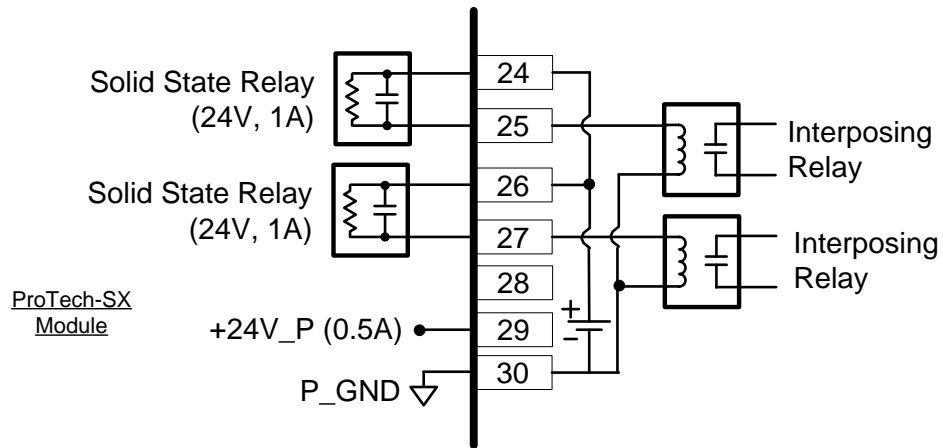

Figure 2-10b. Example Trip Relay Wiring (External Supply)

Relay Outputs (Configurable)

Each ProTech-SX module also has three configurable solid-state relay outputs. These are user-programmable and can be programmed to function as required. The programmable relay outputs have normally-open type contacts and are rated for 24 VDC @ 1 A. Refer to Figure 2-10c or d for wiring information.

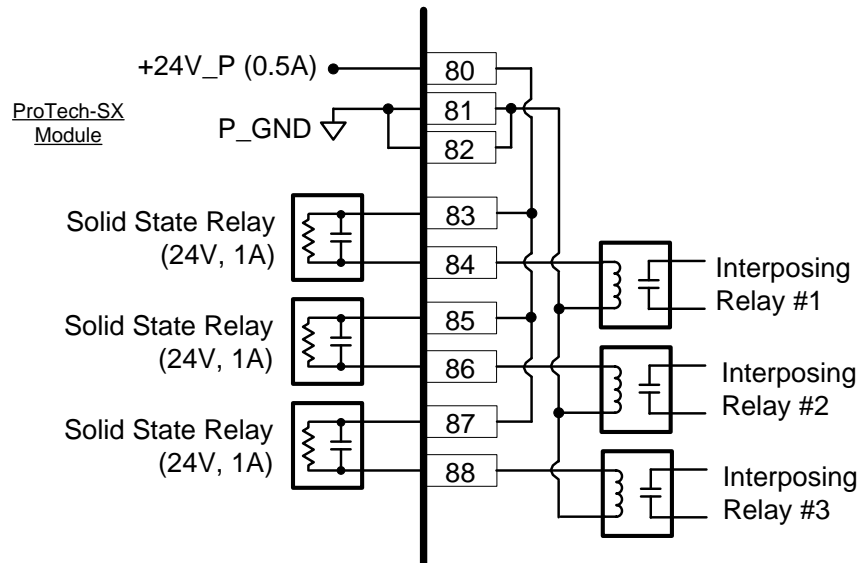

Figure 2-10c. Example Programmable Relay Wiring (Internal Supply)

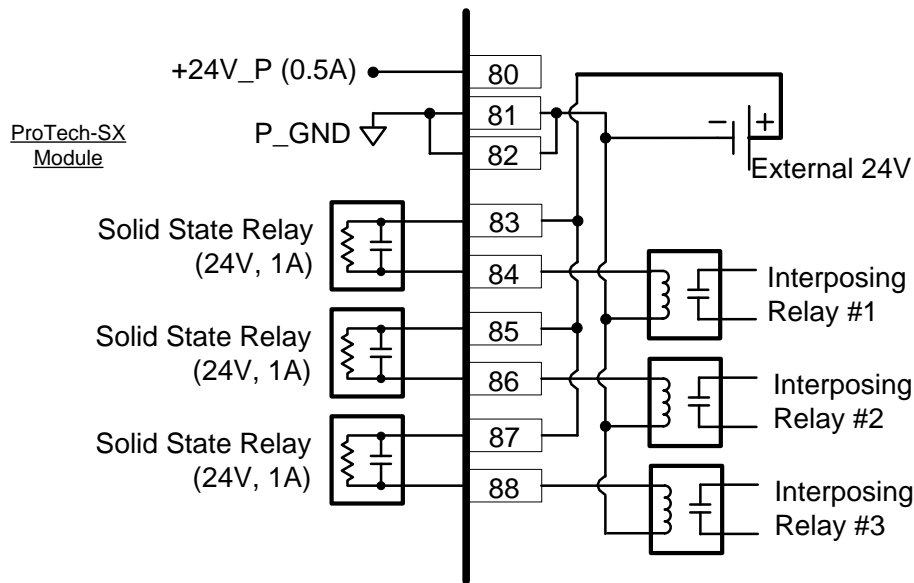

Figure 2-10d. Example Programmable Relay Wiring (External Supply)

Internal Power Supplies for Discrete Signals

Two internal 24 V power supplies are available within each ProTech-SX module for Discrete I/O, one for driving external relay coils and one wetting voltage for configurable inputs (when used as discrete input circuits). Each power supply utilizes an internal circuit shutdown to protect the power supply from over-current conditions.

One power supply channel (+24 V_P) is capable of providing 24 VDC $\pm 10\%$ @ 500 mA maximum output current, to power external relays. This supply is used for relay coils driven by the Independent Trip Relay signals and Programmable Relays. Independent Trip Relay signal connections can be made through terminals 29 and 30 with terminal 30 as common. Coil Voltage for Programmable Relays is on terminals 80, 81, and 82 with terminals 81 and 82 as the commons. Refer to Figure 2-11 for wiring information.

If additional current capability is needed the Voter and Programmable relay connection points may be used as controlled-switch contact connection points with an external power supply. An external supply may be used instead of the internal supply only for the independent trip relays or programmable relays as shown in Figure 2-10d. The external supply should be referenced to terminal 80 or 81.

A second power supply channel (Discrete PWR) is capable of providing 24 VDC $\pm 10\%$ @ 50 mA maximum output current, to power the module's configurable input circuitry (configured as Discrete Inputs). Power connections can be made through terminal 37, with terminal 38 as the common. This power supply is sized to provide power for all ten discrete inputs. Refer to Figure 2-11 for information on the module's internal power supply relationship.

NOTICE

If total current drawn through terminals 37 and 38 exceeds 80 mA the power supply's internal breaker will open. Upon such a condition, all load must be removed from the specified terminals to allow this breaker to reset.

If additional current capability is needed, the DI wetting voltage may come from an external source. If an external supply is used it must be an isolated supply.

NOTICE

If DI wetting voltage is from an external supply, it must be an isolated power supply. The module input 24 VDC power source may not be used. Tying the input power to the Discrete power causes bias offsets which make the supplies susceptible to transients. The supply must also be referenced correctly to Discrete PWR by connecting the two commons.

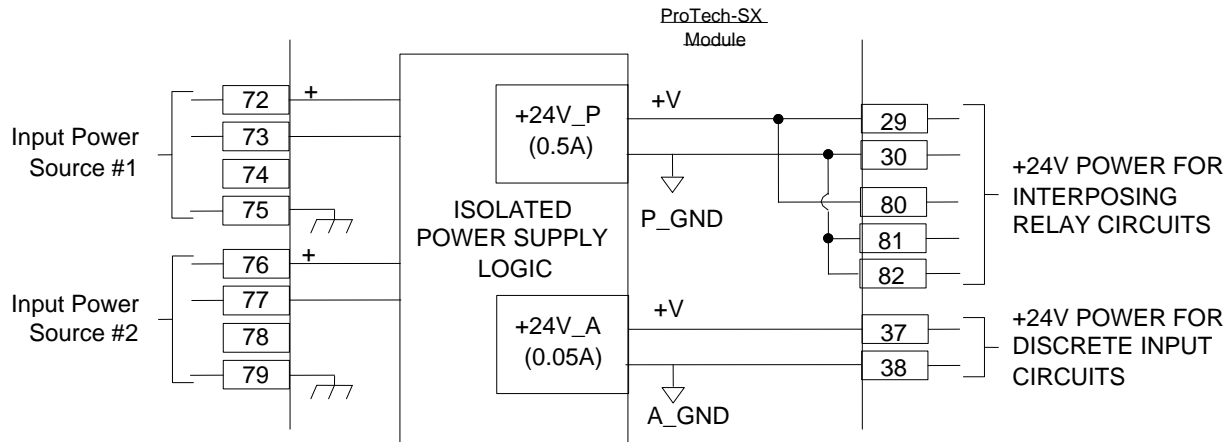

Figure 2-11. Power Supply Relationship Diagram

Serial Modbus Communications

One serial communications port is available for Modbus communications to a plant DCS (distributed control system) or local HMI (human machine interface). This serial port can be wired and configured for RS-232 or RS-485 communications, depending on the specific application requirements. Refer to Figure 2-12a for RS-232 wiring information, and Figure 2-12b for RS-485 wiring information.

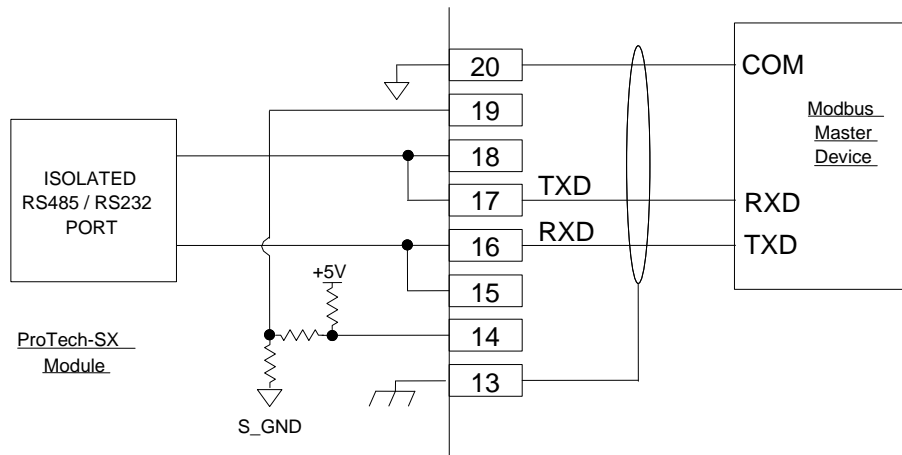

Figure 2-12a. Serial Port Interface Diagram—RS-232

Optional termination resistors for RS-485 communication networks are included within the ProTech-SX control's internal circuitry, and only require terminal block wire jumper(s) for connection to a network, for applications requiring these termination resistors. Refer to Figure 2-12b for jumper connections.

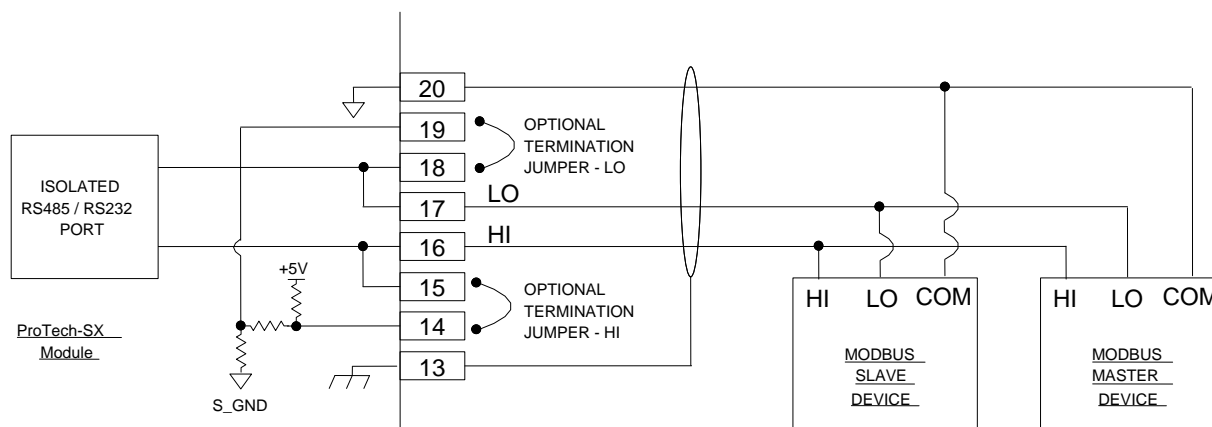

Figure 2-12b. Serial Com Port Interface Diagram—RS-485

Service Port Communications

One 9-pin Sub-D based service port is available to interface with a computer for loading program settings into the ProTech-SX and for reading stored log files from the ProTech-SX, using the Programming and Configuration Tool (PCT). This port is designed to communicate to the computer using a serial DB9 extension (straight-through) type of computer cable.

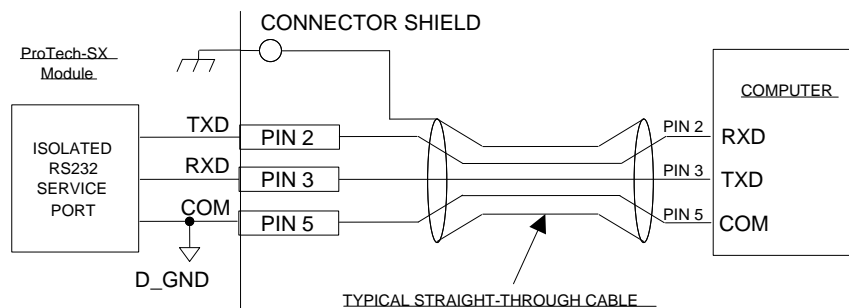

Figure 2-13. Service Tool Cable/Interface Diagram

IMPORTANT

The RS-232 serial cable must be disconnected when not in use. The port is a service port only, it is not designed for permanent connection.

Chapter 3. Functionality

Features

Fault Tolerant Design

The ProTech-SX accepts two speed inputs, seven configurable analog / discrete inputs, and three dedicated function discrete inputs. It also has three configurable relay outputs and one analog output for the sensed speed output.

The ProTech-SX is a SIL-2 (according to IEC-61508) design.

Programming/Configuring Overview

The ProTech-SX module includes preset overspeed, over-acceleration, alarm latch, and trip latch functionality and can be custom-configured to meet a specific application through a module's front panel or the provided Programming and Configuration Tool (PCT).

A custom application program is required for use of any of the ProTech-SX configurable inputs, outputs and related functionality. A software-based PCT is included with each ProTech-SX that can be loaded onto a computer, and used to:

- Create and change custom application programs
- Change speed redundancy mode (single speed, dual redundant speed)
- Change overspeed and over-acceleration functionality settings
- Save application and configuration settings to a file
- Upload application and configuration settings from a ProTech-SX module
- Upload and view stored logged files from a ProTech-SX module

Configuration and program logic changes are allowed while the service tool is connected (on-line) as long as the module is in a tripped state. Configuration and program logic changes can also be made and saved to a settings file with the computer "off-line" (service tool not connected) then loaded into the ProTech-SX later.

Although the overspeed and over-acceleration functionality can be programmed from either the PCT or a module's front panel, changes/additions to a custom application program can only be changed via the PCT. Entry of the correct "configuration" level password is required to perform any program changes or download a program into a module.

Refer to Chapters 9 and 10 of this manual for more information on performing program changes.

Security

The ProTech-SX utilizes two password levels: a Test Level Password and a Config Level Password. The same passwords are used by the Programming and Configuration Tool (PCT) and Front Panel.

The Test Level Password is required to:

- Initiate tests
- Reset logs (except for the Peak Speed/Acceleration Log)
- Change the Test Level Password

The Config Level Password provides access to any function that requires the Test Level Password, as well as:

- Change any program setting
- Download an application program file into a module
- Reset the Peak Speed/Acceleration Log.
- Change the Config Level Password

Each of these passwords meets NERC (North American Electric Reliability Corporation) cyber security requirements.

The default password for Test and Config Level is “AAAAAA”.

Product Models

Two basic ProTech-SX models are available depending on the required power supply options (two high-voltage power supply inputs, or one high-voltage and one low-voltage power supply input).

Each ProTech-SX model can be configured to function for energize-to-trip and de-energize-to-trip applications. The de-energize-to-trip functionality is implemented such that a complete loss of power to the module results in a trip of that module. The energize-to-trip functionality is implemented such that a complete loss of power to the module does not result in a trip of that module.

IMPORTANT Optionally all ProTech-SX models can be configured for de-energize-to-trip or energize-to-trip functionality, based on the application action required. However, de-energize to trip is a safer way to fail so that a total power loss to the control will trip a shut down.

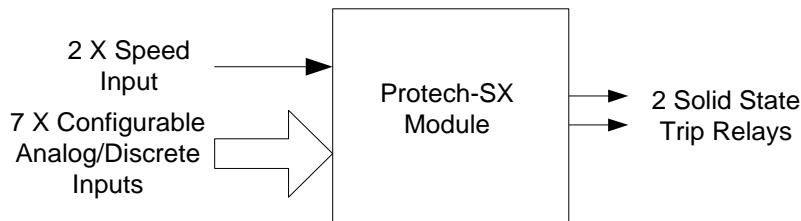

Figure 3-1. Basic Functional Overview

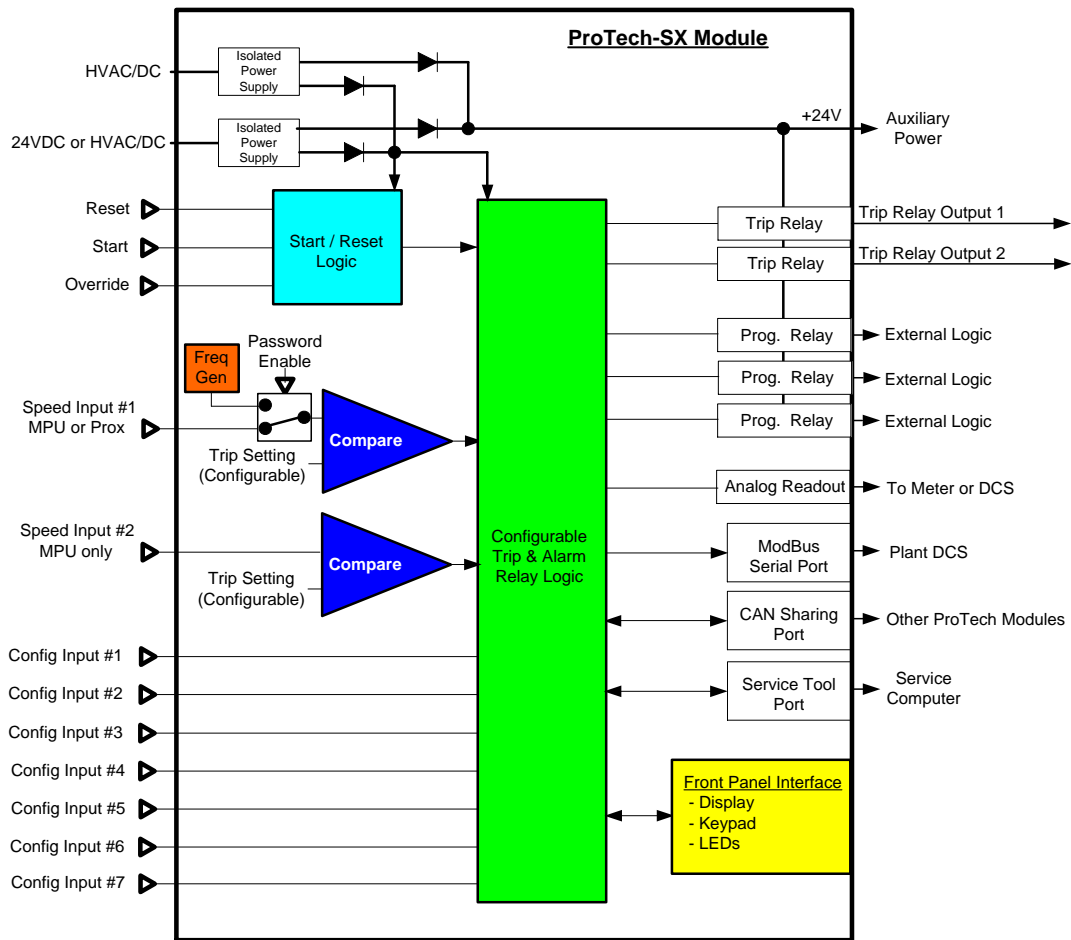

Figure 3-2. Functional Diagram of ProTech-SX module

Power Supplies

Each ProTech-SX system accepts two input power sources (for redundancy). Depending on the ProTech-SX model purchased, the module will accept either two high-voltage (HV) input power sources or one HV input power source and one low-voltage (LV) input power source. For reliability purposes, each ProTech-SX module will function normally with power sourced to both or either power supply input.

Inputs and Outputs

Speed Sensor Inputs

Each module has two speed inputs. Speed input 1 can be programmed to accept a passive MPU (magnetic pickup unit), or an active speed sensor (proximity probe signal or an eddy current probe signal), speed input 2 only accepts a passive MPU and cannot be configured.

When in "Passive" mode, special MPU open-wire detection circuitry is used to validate that the MPU is properly connected before turbine operation, and special loss-of-speed detection logic is used to validate speed sensor functionality during turbine operation. The open-wire detection as well as the loss-of-speed detection logic is independently operated on both speed inputs.

Depending on the module's program settings a loss of speed signal or open-wire detection will result in a trip or alarm condition.

IMPORTANT

MPU open-wire detection logic and associated trip/alarm action is only utilized when the speed input is configured as a “passive” probe.

When configured as an MPU signal input, the speed sensor circuitry will sense MPU signals within the voltage range of 1—35 Vrms.

When configured as a proximity (active) probe input or eddy current probe input, a 24 V power supply is provided to power the probe, but an isolated external supply may be used instead, if referenced correctly.

The number of gear teeth and the gear ratio are configured to convert the frequency input from the speed probe to the unit speed.

WARNING

The number of gear teeth and the gear ratio must match the actual unit hardware or speed sensing and all associated protection and functionality will not work correctly.

NOTICE

For process-safety-based applications where speed is not sensed or used, the speed input can be disabled by putting a jumper across the sensor input terminals and disabling the ProTech-SX control’s internal start logic.

Dedicated Discrete Inputs

The ProTech-SX module accepts three dedicated discrete inputs. The Preset Contact Inputs are Start, Reset and Speed-Fail-Override.

Start

This contact input is used as part of the Start Logic “Speed Fail Timeout Trip” function. When this function is Enabled, closing the Start contact will start the Speed Fail Timeout timer. This is an edge-triggered signal and re-selecting Start will re-start this timer. Refer to the Start Logic section below for additional details.

Reset

This contact is used to clear module trips and alarms.

Speed-Fail-Override

This is used as part of the Start Logic “Speed Fail Trip” function. When this function is Enabled, closing the Speed-Fail-Override contact overrides the Speed Fail Trip. This is a level-sensitive trigger, so the contact must remain closed to prevent the Speed Fail Trip until the speed is greater than the speed fail setpoint. Refer to the Start Logic section below for additional details.

Configurable Inputs

Each module has 7 configurable analog/discrete inputs. Each input can be configured as Not Used, Analog Input, or Discrete Input. User-defined names can be associated with each input.

Discrete Input Configuration Example

When configured as a discrete Input, the channel accepts a 0 / 24 VDC discrete input. NOTE: <6 VDC = FALSE, >12 VDC = TRUE. The Boolean output associated with the discrete input can be used in the user configured software.

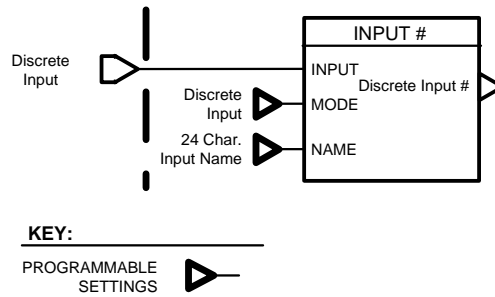

Figure 3-3. Discrete Input Example

Analog Input Configuration Example

When configured as an analog input, the channel accepts a 4–20 mA analog signal. The accuracy of the analog input is better than $\pm 0.5\%$ of 20 mA over the temperature range of the product. Engineering units and ranges are assigned to the 4–20 mA current input values. Additionally, low-low (LoLo), low (Lo), high (Hi), and high-high (HiHi) levels can be defined. The Boolean outputs associated with these levels for the analog input can be used in the user-configured software. There is also a Range Error output to indicate that the Input is outside a 2–22 mA range. All of these outputs are non-latching.

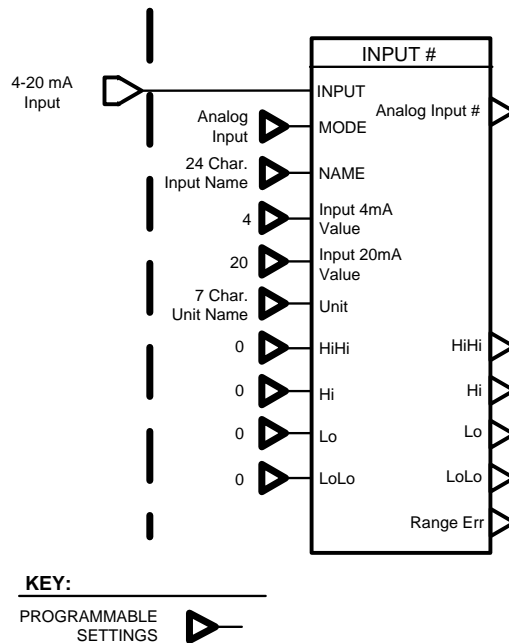

Figure 3-4. Analog Input Example



WARNING

The analog scaling must match the actual unit hardware, or the signal sensing and all associated protection and functionality will not work correctly.

Configurable Relay Outputs

Each module has 3 configurable Relay Outputs. Each relay output can be configured to reflect the state of any Boolean value within the module. Each output can be configured to be inverting or non-inverting. If configured as non-inverting, the relay will energize when the configured input is true. The first configurable relay is defaulted to the output of the Alarm Latch.

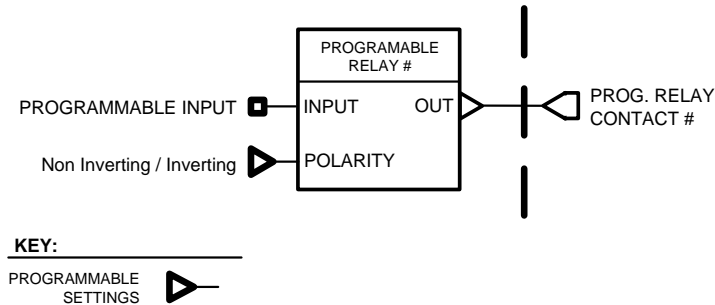

Figure 3-5. Programmable Relay Output Diagram

Analog Output

A single 4–20 mA output is provided on each module to indicate the speed sensed by that module. The 4–20 mA range can be configured to any speed range desired. The accuracy of the analog output is better than $\pm 0.5\%$ of 20 mA over the temperature range of the product.

Overspeed and Over-Acceleration Detection and Trip

Each ProTech-SX includes overspeed and over-acceleration functionality and can be custom configured to meet specific application overspeed and over-acceleration requirements. No custom application program is required to be loaded for this functionality to operate normally.

The ProTech-SX senses speed and then compares the sensed speed to its programmed overspeed trip setpoint to detect an overspeed condition and generate a trip command.

The ProTech-SX derives acceleration from the sensed speed and then compares the sensed acceleration to its programmed over-acceleration trip setpoint to detect an over-acceleration condition and generate a trip command. The ProTech-SX control's acceleration detection function can be configured to be enabled or disabled, or only enabled above a certain speed setpoint, depending on the specific application's requirements. The over-acceleration trip range is configurable from 0 to 25 000 RPM/s.

Peak speed and peak acceleration are tracked and logged for every overspeed and over-acceleration occurrence, the last 20 occurrences logged and can be viewed from the front panel or loaded to a computer via the ProTech-SX Programming and Configuration Tool (PCT).

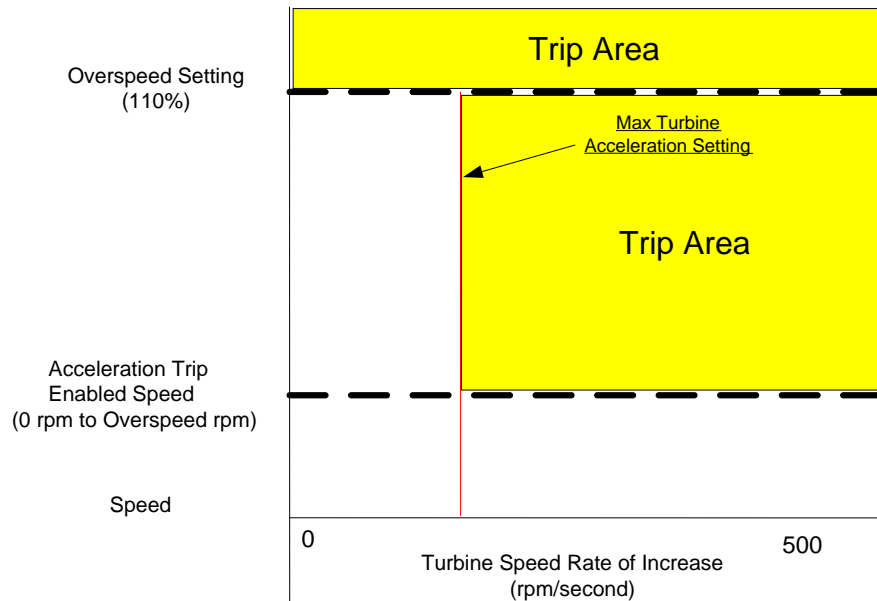

Figure 3-6. Over-Acceleration Enabling Diagram

Start Logic

The ProTech-SX logic solver's failed speed signal detection logic is used to sense no/zero speed and issue a trip command. However, before a prime mover is started and as its speed gear begins to turn, magnetic speed probes output a zero rpm signal until the speed exceeds the probe's minimum frequency.

The Protech-SX has two methods for turbine start. The user should select only one of these options:

- Speed Fail Trip—uses the dedicated speed fail override input (terminals 5/6) to override the speed sensor trip until the 'Speed Fail Setpoint' is reached
- Speed Fail Timeout Trip—uses the start command to initiate a timer that overrides the speed signal for a set period of time. If the 'Speed Fail Setpoint' is not reached by the expiration of this time then unit will trip.

Note that these functions only override the trip due to a failed speed signal—they do not override any other trips.

Speed Fail Alarm

If the speed fail alarm is enabled, an alarm will be set 'True' anytime the speed is below the 'Speed Fail Setpoint'

Speed Fail Trip

If the "Speed Fail Trip" is Enabled, the Speed-Fail-Override is used to override the speed fail trip logic. When the contact is open, the sensed speed must exceed the Speed Fail Setpoint, otherwise a Speed Fail Trip occurs.

For example, if there is a failure in the speed probe before the contact is opened, the Speed Fail Trip function will detect the missing speed signal and trip the module.

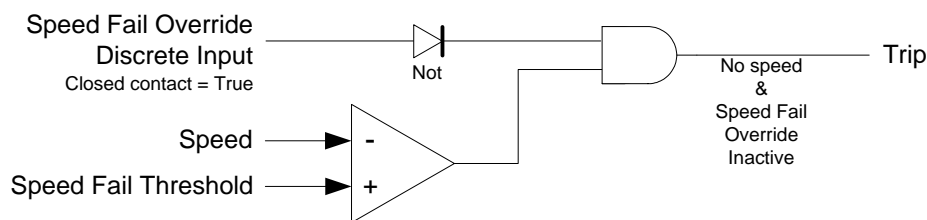

Figure 3-7. Speed Fail Trip Diagram

Speed Fail Timeout Trip

If the “Speed Fail Timeout Trip” is Enabled, the sensed speed must exceed the Speed Fail Setpoint within the Speed Fail Timeout Time after a Start signal occurs, otherwise a Speed Fail Timeout Trip occurs.

IMPORTANT

The Speed Fail Timeout trip is cleared by the reset function (the trip and alarm reset function, not the reset input to the timer in the diagram below), even if speed is still below the Speed Fail Setpoint.

The start signal is generated by selecting the START button on the front panel of the module or by closing the predefined Start contact input. The start signal is edge triggered and re-selecting Start will reset the timer.

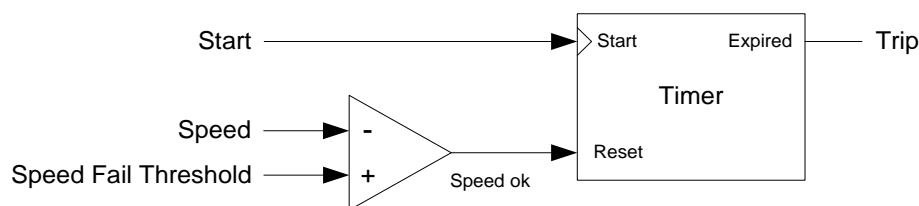

Figure 3-8. Speed Fail Timeout Trip Diagram

Start Example with Speed Fail Timeout Trip

First, any trips or alarms are cleared by issuing a reset command either by pressing the Reset key, or by momentarily closing the Reset contact, or by issuing the Reset command via Modbus.

When the turbine is ready to be started, the Speed Fail timer is started by pressing the Start key, or by momentarily closing the Start discrete input. The timer expires when it reaches the Speed Fail timeout value. If speed does not exceed the Speed Fail setpoint before the timer expires, the unit trips.

If the unit is being restarted after a normal rolldown (that is, there was no trip), the unit does not require a reset. The Speed Fail trip is overridden because the Speed Fail timer is cleared whenever speed exceeds the Speed Fail setpoint. The Speed Fail timer should be started by the operator when the turbine is ready to be started again.

NOTICE

For the Speed Fail timeout trip function to provide the intended fault detection, Start must be selected when the turbine is to be started.

The timer can only be started when speed is below the Speed Fail setpoint. Selecting Start has no effect if speed is above the Speed Fail setpoint.

Configurable Logic

The ProTech-SX provides configurable, or user-definable, logic to implement custom safety/protection and test programs. This can be used in conjunction with the configurable inputs and user-definable alarms and trips to monitor values such as lube oil pressure, vibration, trip manifold status, and provide parameter monitoring functions. Configurable logic is also used to implement the user-defined test functionality. It is possible to generate (and reset) module trips, alarms, or events and to use the associated logs and trip cycle time monitoring as part of the safety system test validation.

The logic unit provides configurable logic that allows the user to define how the input signals are used in detecting an unsafe condition and generating a trip signal.

The configurable logic provides the following functions:

- Analog comparators
- Boolean logic (AND, OR, NOT, etc.)
- Boolean latches
- Delays
- Timers

The user is responsible for validating that the configured logic unit's input-to-output behavior performs as expected, with the intent of confirming the following:

- Verify that the logic unit was configured as intended
- Verify that the documentation for the logic unit has been correctly understood and applied
- Verify that the information presented to the user by the Programming and Configuration Tool (PCT) is correct

Functional Examples

IMPORTANT

For robust programming and reliability system fault response, it is recommended that the programming features are also used to sense out of range conditions. For example, when using a configurable input in analog mode, this can be done by using the Lo, LoLo, Hi and HiHi setpoints.

Trip Cycle Time Monitoring

The ProTech-SX can monitor and log the time it takes for the valve to actually close from the time a Trip command is issued. To do this, one of the configurable inputs must be configured as a discrete input and then assigned as a Trip Indicator Input (under the Trip Cycle Timers screen in the PCT). A discrete input position feedback signal from the valve must then be connect to this input, that indicates to the Protech-SX that the valve is in the Tripped position (either open or closed).

This function also has a Maximum Cycle Time setting. The unit will trigger an alarm if the response time is more than this value, which could indicate some problem with the trip system.

Process Parameter Monitoring and Trip

The logic unit has inputs to measure process parameters (continuous or discrete signals). These signals might represent such values as lube oil pressure, thrust, vibration, system hydraulic pressure, valve position, additional trip inputs, or other values significant to the safety system. Comparators, Boolean logic, and timers can be used to implement relatively sophisticated algorithms including, noise suppression, test functions, alarming, and trip functions based on these signals.

Trip System Testing

The system can be programmed to implement the user-defined tests to activate relay outputs (or even generate a trip from the module) to actuate a part of a trip system. The user-configurable inputs can be defined to monitor and log the test results. This might include monitoring a change of pressure or a limit switch to confirm the functionality of the system tested. After the test is completed, or after some time delay, if there is a test failure, the trip test sequence can restore the system to the normal state. When the normal state of the system is confirmed the user-defined test can be reset. The event latch might be used to confirm the progress and success or failure of the test steps.

Test Routines

Each ProTech-SX module provides a variety of test routines to support common test requirements. The ProTech-SX also supports 3 User-Defined Tests.

In general, a test may not be started if the module is tripped or in test mode already. One exception to these rules is the Temporary Overspeed Trip Setpoint(see below). The other is the Lamp Test, which can be applied at any time without a password. If a test is not permitted, or aborted, messages displayed on the front panel explain the cause.

Any test may be initiated (or cancelled) from the ProTech-SX Front Panel. Modbus provides commands to initiate the Auto Speed Test or any of the User-defined Tests. User-defined Tests can be started through configurable logic – so a discrete input might be defined to initiate a test.

NOTICE

For Modbus commands, a start confirmation is required, and an abort is also provided.

Temporary Overspeed Setpoint

Settings for this test are found under Configure Menu\ Test Modes

- Temporary Overspeed Trip
- Temp. Overspeed Trip Timeout

This feature temporarily replaces the Overspeed Trip setpoint with a different value for testing. The Temporary Overspeed Setpoint can be higher or lower than the normal overspeed trip setting.

NOTICE

When the Temporary Overspeed Setpoint is set above the normal overspeed trip, it should not be set above the maximum speed allowed for the unit.

The Temporary Overspeed Setpoint is designed to allow users to easily test the module's overspeed function at level lower than the normal overspeed setting or to test the overspeed function of a mechanical bolt or other overspeed protection system at a higher speed than the normal overspeed trip setting.

An alarm is generated when this test is enabled. Also, there is a Temporary Overspeed Trip Timeout feature that prevents an operator from "forgetting" to disable this test. The timeout can be configured from 0 to 30 minutes. When the test is enabled, the timer starts, if it reaches the timeout value, the test is automatically aborted.

Once the module is in its tripped state, this test is disabled and the module's Overspeed Setpoint is returned to its normal setting.

Simulated Speed Tests

Settings for this test are found under Configure Menu\ Test Modes

- **Simulated Speed Timeout**

There are two tests that use an internally-generated speed signal to test the module's Overspeed Trip setpoint and Trip output function. The ProTech-SX is defaulted to use the Test Mode Interlock so that a module cannot be placed in test. If it is desired to test a unit trip, the Test Mode Interlock can be disabled.

Manual Simulated Speed Test

This allows the user to manually increase/decrease the module's internal frequency generator to perform a test of the Overspeed Trip function. This test can only be performed from the front panel of the ProTech-SX.

When the test is initiated, the frequency generator automatically starts at 100 rpm below the overspeed setpoint. Then the operator can adjust the simulated speed up or down from the front panel of the ProTech-SX.

When the Overspeed Trip occurs, it is logged in the module's trip log and noted as a test.

An alarm is generated while this test is enabled. Also, there is a Simulated Speed Timeout feature that prevents an operator from "forgetting" to disable this test. The timeout can be configured from 0 to 30 minutes. When the test is enabled the timer starts, if it reaches the timeout value, the test is automatically aborted. The operator can abort the test at any time.

At the conclusion of the test, the unit will be tripped and a reset command is required to reset the Protech-SX.

Auto Simulated Speed Test

This test allows users to easily test the module's Overspeed Trip function by having the module's frequency generator automatically ramp up to and above the module's overspeed set point. This can be initiated from the front panel or via Modbus. The auto test starts at 100 rpm below setpoint. Then the frequency generator ramps up at approximately 10 rpm/s until the Overspeed Trip occurs.

When the Overspeed Trip occurs, it is logged in the module's trip log and noted as a test.

To initiate the Auto Simulated Speed Test via Modbus, the Initiate Auto Speed Test command (Modbus address 0:0102) must be followed by the Confirm Auto Speed Test (Modbus address 0:0101) within 10 seconds. The intent of the confirmation is to prevent an erroneous signal from initiating a test. The test can be aborted from either the front panel or via Modbus.

At the conclusion of the test, the unit will be tripped and a reset command is required to reset the Protech-SX.

User-Defined Test

Each module supports three User-Defined test latches in the configurable logic. These latches allow the users to configure custom test routines as needed to test their system.

These User-Defined tests are intended to support automated tests of such systems as trip manifolds, parameter monitoring functions, or other user-specific systems. The associated logic may be simple or complex, depending on the nature of the system to be tested.

These tests may include tripping the module and checking the performance of a single channel in a trip manifold using the trip cycle time monitoring functions, and then resetting the module.

All the test logic must be programmed with the configurable logic. The User-Defined Test latches are intended to initiate the tests and to signify and manage the end of the test, including an aborted test.

NOTICE

The logic behind the User-Defined Test must be validated by the user for all possible modes of operation including normal test, test failure(s), or test abort.

These latches share some of the same properties as the pre-defined test routines. A test cannot be initiated while any other test routine is active. User-Defined tests can be initiated from the front panel (with password), via Modbus (with confirmation), or through configurable logic (which allows connection to any Boolean value including Discrete Inputs).

An alarm is associated with each test latch. Also, there is a Timeout feature associated with each User-Defined Test latch that prevents an operator from “forgetting” to disable this test. The timeout can be configured from 0 to 30 minutes (1800 seconds) with 1 second resolution. When the test is enabled, the timer starts—if it reaches the timeout value, the test latch is automatically reset. The test latches can be reset from the configurable logic, or from the front panel, or via Modbus.

Alarm, Trip, and Event Latches

The ProTech-SX provides pre-defined, user-configurable and user-defined alarms and trips. This makes it easy to utilize common functions but allows great flexibility to customize the ProTech-SX to meet a user’s specific needs. The fully configurable Event latches make it possible to record additional information such as test results or to provide more detail on alarm or trip events.

Reset Function

The Reset Function is associated with all of the following latches. A Reset can be generated by pressing the Reset key on the front panel, from the pre-defined Reset contact input, via Modbus, or from the user-defined “Configurable Reset Source”.

It is possible to configure one Discrete Input to function as a Resettable Trip input where the Reset Function will clear the associated trip (with this single input) even if the contact is still open. This is used in cases where the ProTech-SX trip must be cleared to reset a tripped system which feeds back a trip status that trips the ProTech-SX.

Alarm Latch

An “alarm” refers to an action of the ProTech-SX module to bring some condition to the attention to the user. When any of the Alarm Latch inputs becomes true, the output of the alarm latch is set TRUE. The yellow ALARM light is illuminated on the front panel. By default, the Configurable Relay #1 is connected to the Alarm latch (but this can be changed with the Programming and Configuration Tool (PCT) software). Each Alarm Input is individually latched, and those latched outputs are available on Modbus. The individual latches are reset by the Trip Reset function if the input is false. The Alarm Latch output remains TRUE until the Reset function occurs and all inputs are false.

Here is the complete list of possible Alarm Latch inputs:

- Speed Fail (if configured)
- Internal Fault Alarm
- Power Supply 1 Fault
- Power Supply 2 Fault
- Tmp Ovrspd Setpoint On
- Manual Sim. Speed Test
- Auto Sim. Speed Test
- User Test 1 Active (if configured)
- User Test 2 Active (if configured)
- User Test 3 Active (if configured)
- Trip Cycle Time Mon 1 (if configured)
- Trip Cycle Time Mon 2 (if configured)
- User configurable Alarms 1-50 (if configured)

Note: The user can define the name associated with each user-defined Alarm.

Trip Latch

A "trip" of the module refers to the action of the ProTech-SX module changing the state of its Trip output. When any of the Trip Latch inputs becomes true, the output of the Trip Latch is set TRUE. The red TRIPPED light is illuminated on the front panel. The module trip relays are put in the trip state (which could be configured as energized or de-energized). Each Trip Input is individually latched, and those latched outputs are available on Modbus. The individual latches are reset by the Reset function if the input is false. The first input to set the Trip latch, or First Out (FO), is also latched. This First Out indication is available in the trip log and on the Modbus. The Trip Latch output remains TRUE and the First Out indication remains unchanged until the Reset function occurs and all inputs are false.

IMPORTANT

When configured as de-energize-to-trip, the module powers up in the tripped state. When configured as energize-to-trip, the module powers up such that it does not enter the tripped state unless a trip condition is present.

IMPORTANT

The logic unit requires that it be in the tripped state in order to change the configuration.

The user can reset a trip by pressing a button on the unit's front panel, or by activating a discrete input that is dedicated to the Reset function.

Here is the complete list of possible trips:

- Power Up Trip
- Configuration Trip
- Parameter Error Trip
- Internal Fault Trip
- Overspeed Trip
- Over-Acceleration Trip (if configured)
- Speed Probe Open Wire (if configured)
- Speed Lost Trip (if configured)
- Speed Fail Trip (if configured)
- Speed Fail Timeout Trip (if configured)
- Resettable Trip Input Trip (if configured)
- User Configurable Trips 1-25 (if configured)

Note: The user can define the name associated with each user-defined Trip

Event Latches

In each module, three Event Latches are provided. These are to be used in conjunction with the User-Defined software and can be used to log any desired event. The latch is structured like the Trip Latch.

For a given Event Latch, when any of the Event Latch inputs becomes true, the output of the Event latch is set TRUE. Each Event Input is individually latched, and the latched outputs are available on the Modbus. The individual latches are reset by the Reset function if the input is false. The first input to set the Event latch, or First Out (FO), is also latched. This First Out indication is available in the Event log and on Modbus. The Event Latch output remains TRUE and the First Out indication remains constant until the Reset function occurs and all inputs are false.

Each event latch provides 25 user-configurable Inputs. The user can define the name associated with each user-defined Event.

System Logs

The ProTech-SX logs (saves to memory) all trips, alarms, events, trip cycle times, and overspeed events. Peak speed and acceleration are also logged. The logs can be viewed from the front panel of the ProTech-SX or from the PCT tool. With PCT tool, the Configuration Error Log can also be viewed. The logs can be exported from the PCT tool.

The logs are stored in non-volatile memory so loss of power to the ProTech-SX will not affect this information. The log functions use scrolling buffers that keep the most recent data. The individual log sizes are described in the following descriptions. Logs can be cleared from the front panel with the appropriate password. The Test Level Password is needed to reset All Logs except of the Peak Speed/Acceleration Log. The Config Level Password is required to reset the Peak Speed/Acceleration Log.

Overspeed/Acceleration Log

Any time an overspeed or over-acceleration event occurs, the date and time of the trip, the speed and acceleration values at the trip time, and the maximum speed and acceleration will be recorded. If the trip occurred during testing, this will also be noted in the log. The log will save the last 20 overspeed or over-acceleration events.

Trip Log

The module logs the last 50 trips. The log holds the trip description, the date and time of the trip, whether it was the “first out” trip, and whether the module was performing a test when the trip occurred.

Alarm Log

The Alarm Log stores the last 50 alarms. The log holds the alarm description, the date and time of the alarm, and whether the module was performing a test when the alarm occurred.

Trip Cycle Time Log

If Trip Cycle Time monitoring is configured, the module logs the trip cycle times for the last 20 trips. Whenever a module trip occurs, two trip cycle time monitors can be configured to monitor the milliseconds from the trip until a user-defined Trip Indicator Input is true. For example, the Trip indicator could be configured to be a limit switch which indicates that a trip valve has closed, or a pressure comparison that indicates that the system or part of the trip system has actuated. The Trip Cycle Time Monitors are designed to monitor the performance of the trip system and detect any degradation of its response time to warn the user before a potentially dangerous condition exists.

The Maximum Cycle Time for each event can be specified as 1 to 60 000 ms. If this time is exceeded, an alarm will be generated. If the event has not occurred in 10x this maximum cycle time (up to a maximum of 60 seconds), then the trip cycle time will be set to 60 seconds.

Event Logs

Three event logs are provided. Each log records events seen by Event Latches 1, 2, and 3, respectively. The last 50 events on each Event Latch are logged. Each Event Latch has 25 inputs. Event Latch inputs can be configured to record any Boolean variable and associate a 24-character user-defined name with that event.

Peak Speed/Acceleration Log

The maximum speed and acceleration detected by the module will be logged. This includes values generated by internal simulation testing. As this is intended to be a maximum value capture, no date or time information is associated with these values. This can be reset from the front panel with the Config Level Password.

Response Time Performance

The response time is less than 12 ms (**Note 1**) measured from detection of overspeed or out-of-range process to assertion of the trip relays.

No operator intervention via the operator interface is required for the logic unit to perform the safety functions.

Note 1: See the following charts for measured response time. The response time specifications are valid for measured frequencies of 2 kHz and higher. For this reason, it is highly recommended that the user use speed wheel gearing that provides the ProTech with a frequency of at least 3 kHz for the normal operating speed. The internal frequency is calculated from RPM and number of gear teeth:

$$\text{Frequency} = (\text{rpm}) * (\text{number of teeth}) / 60$$

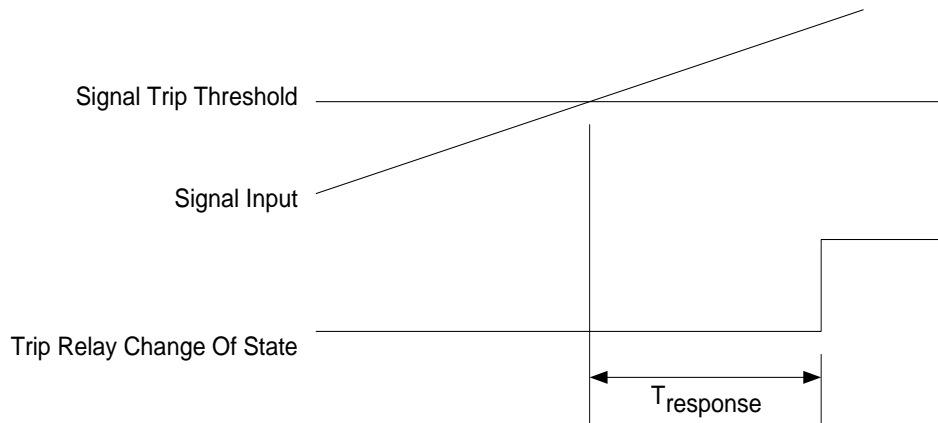

Figure 3-9. Response Time Definition

Analog Output

The response time of the analog output is less than 10 ms measured from a change in speed to a change in the output current.

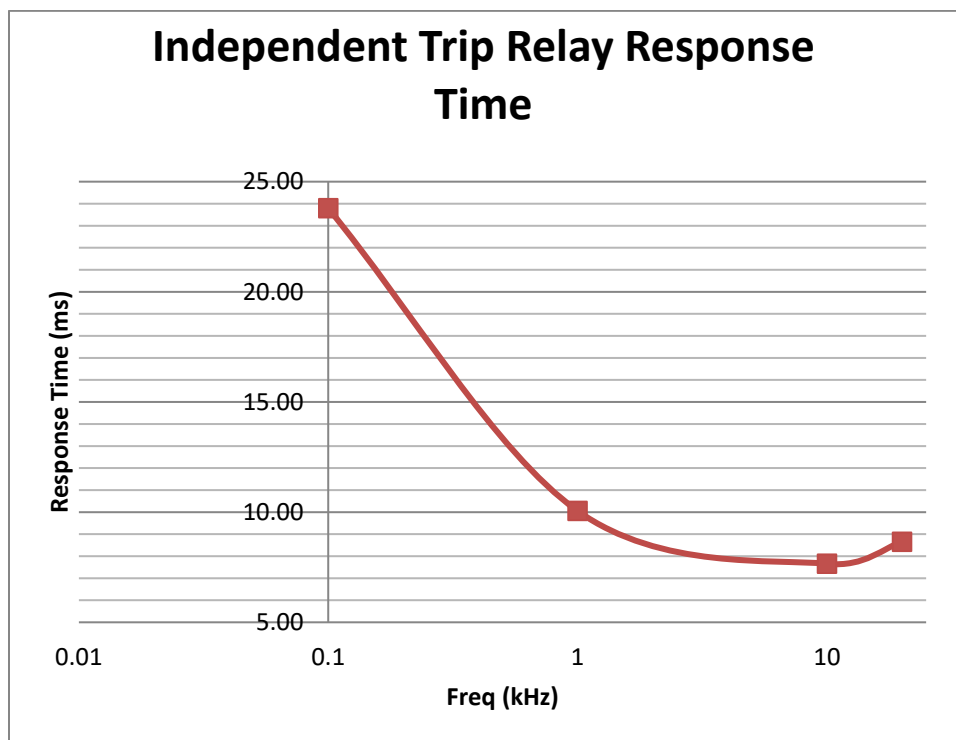

Figure 3-10. Trip Relay Response Time (Typical) Graph

Chapter 4.

Modbus Communications

Modbus Communications

The ProTech-SX can communicate with plant distributed control systems and/or CRT based operator control panels through the Modbus communication port. The module has a serial port for Modbus communications. This port supports RS-232 or RS-485 communications using a standard Remote Terminal Unit (RTU) Modbus transmission protocol. Modbus utilizes a master/slave protocol. This protocol determines how a communication network's master and slave devices establish and break contact, how a sender is identified, how messages are exchanged, and how errors are detected.

Monitor Only

The Modbus communication port is designed to continually output all Boolean and analog "read" information, and can be configured to accept or ignore "write" commands, depending on the specific application's requirements. This allows the ProTech-SX to be monitored but not controlled from any external device.

Once a Modbus port's "Enable Write Commands" setting is configured "No", the ProTech-SX module will not accept "write" commands from an external master device (DCS, etc.). For security purposes, the option to ignore "write" commands can only be enabled or disabled with a configuration-level password.

Monitor and Control

Once the Modbus port's "Enable Write Commands" setting is configured "Yes", the ProTech-SX module will accept "write" commands from an external master device (DCS, etc.). This allows a Modbus compatible device to monitor all read registers and issue "Reset" and "Start/Abort Test Routines" commands only

To ensure that a Modbus based test command is valid, both "Initiate Test" and "Confirm Test" commands must be received to initiate a test routine. A Confirm must be received within 10 seconds or the sequence must be re-initiated. A module will only accept an Initiate Test command and perform the requested test if the module is healthy, not tripped, and not in a test mode.

Modbus Communication

The ProTech-SX Modbus communications port is designed to function as a slave device on a Modbus network using the industry-standard Modbus RTU (remote terminal unit) transmission protocol. For more information on Modbus networks and the RTU transmission protocol, refer to Modbus Protocol Reference Guide PI-MBUS-300 Rev. J.

A Modbus function code tells the addressed slaves what function to perform. The following table lists the function codes supported by the ProTech-SX:

Table 4-1. Supported Modbus Function Codes

Code	Definition	Reference Address
02	Boolean Read Registers (Status of Alarms/Shutdowns, Discrete input/outputs)	1XXXX
04	Analog Read Registers (Speed, Acceleration, etc)	3XXXX
05	Boolean Write Registers (Reset and Test Initiate Commands)	0XXXX

As a slave Modbus device, the ProTech-SX is not responsible to sense or annunciate Modbus link communication errors. However, for troubleshooting purposes, the ProTech-SX will display a “Link Error” message in its “Monitor Modbus” screen if a Modbus transaction request is not received within its five-second time-out period. This error message is automatically cleared when Modbus communications are re-established.

Port Adjustments

Before the ProTech-SX can communicate with the master device, the communication parameters must be verified to match the master device’s protocol settings. For security purposes, these parameters can only be set in the module’s Configuration mode.

Table 4-2. Modbus Communication Port Settings

Parameter	Range
Mode:	RS-232 or RS-485
Baud Rate:	19200 TO 115200
Comm Parity:	NONE, ODD or EVEN
Slave Address:	1 - 247
Enable Write Commands:	Yes or No

ProTech-SX Parameter Addresses

Each available read or write parameter has a unique Modbus address. A complete list of the available parameters and their addresses is located at the end of this chapter. This list consists of Boolean Write, Boolean Read, and Analog Read parameters. Analog write parameters are not used or available with this device.

All values that can be addressed by Modbus are considered to be discrete and numeric. The discrete values are a 1 bit binary on or off value, and the numeric values are 16 bit values. Discrete values are sometimes referred to as coils or digitals, and numeric values are referred to as registers or analogs. All read/write registers are interpreted by the ProTech-SX as signed 16 bit integer values.

Since Modbus can only handle integers, values that require a decimal point in the Modbus Master Device are multiplied by a scaling constant before being sent by ProTech-SX. See the Modbus list for the scaling used on each analog parameter.

Boolean Writes (Code 05)

Boolean Write registers are used by an external master device (plant DCS, etc.) to issue Boolean commands to a ProTech-SX module. The available write commands are listed in Table 4-2.

Once a Modbus port’s “Enable Write Commands” setting is configured “Yes”, the ProTech-SX module will accept “write” commands from an external master device (DCS, etc.).

Note: All write commands are edge-triggered.

Initiating a test mode

Only one test mode can be active at a time. Attempts to start a test are ignored when another test mode is active.

Speed/user tests must be requested by first setting the Initiate bit, followed by setting the confirm bit. If the Confirm bit is not set within 10 seconds after the initiate bit is set, then the test will not be requested.

Note that the confirm-initiate addresses are in reverse order so that an initiate followed by a confirm cannot be executed by a single write command. Both bits must be set to 0 before starting the initiate - confirm sequence.

If an Abort command is set to 1, an initiate-confirm sequence shall be ignored.

Boolean Reads (Code 02)

Boolean Read registers are used by an external master device (plant DCS, etc.) to read the status of internal ProTech-SX module signals (hardware inputs, logic blocks, hardware outputs, etc.). A Boolean read register will have the value 1 if the status of the monitored signal is true and a 0 if false. The available Boolean read registers are listed in Table 4-3.

Analog Reads (Code 04)

Analog Read registers are used by an external master device (plant DCS, etc.) to read the value of internal ProTech-SX module signals (hardware inputs, logic blocks, hardware outputs, etc.). An example of an analog read value would be actual speed.

With the Modbus protocol, analog values are transmitted as 16-bit integer values ranging from -32767 to +32767 (if signed) or 0 to 65535 (if unsigned). Since Modbus can only handle integers, values that have a decimal point are multiplied by a constant before being sent by Modbus. For example, input registers may be listed as the Modbus value `x100` within the listed parameter table. Some values, like the Timer values, are sent using more than one register. The available Analog read registers, units (scaling), and range are listed in Table 4-3.

Heartbeat indication (1:1300)

The Heartbeat indication provides an indication that toggles every 1 second between logic 1 and logic 0.

Last Trip time and date indication (3:0701 - 707)

Last Trip Date/Time represents the Date/Time of the most recent first out trip.

Unit Health indication (3:0801)

The unit health status indicates the state of the internal fault trip (if known) as follows:

0 = internal fault trip is TRUE (Unit Health LED is **red**)

1 = internal fault trip is FALSE (Unit Health LED is **green**)

2 = state of the internal fault trip is unknown because of a communication fault (Unit Health LED is off)

Table 4-3. Boolean Write Addresses (Code 05)

ADDRESS	DESCRIPTION
0:0001	Reset
0:0101	Confirm Auto Speed Test
0:0102	Initiate Auto Speed Test
0:0103	Abort Auto Speed Test
0:0201	Confirm User Defined Test 1
0:0202	Initiate User Defined Test 1
0:0203	Abort User Test 1
0:0301	Confirm User Defined Test 2
0:0302	Initiate User Defined Test 2
0:0303	Abort User Test 2
0:0401	Confirm User Defined Test 3
0:0402	Initiate User Defined Test 3
0:0403	Abort User Test 3

Table 4-4. Boolean Read Addresses (Code 02)

ADDRESS	DESCRIPTION	ADDRESS	DESCRIPTION
1:0001	Internal Fault Trip	1:1027	Analog In 1 Range Err
1:0002	Power Up Trip	1:1028	Discrete Input 1
1:0003	Module Config Trip	1:1029	Analog Input 2 HiHi
1:0004	Parameter Error Trip	1:1030	Analog Input 2 Hi
1:0005	Over Speed Trip	1:1031	Analog Input 2 Lo
1:0006	Over Accel Trip	1:1032	Analog Input 2 LoLo
1:0007	Speed Probe 1 Open Wire Trip	1:1033	Analog In 2 Range Err
1:0008	Speed Input 1 Lost Trip	1:1034	Discrete Input 2
1:0009	Speed Input 2 Lost Trip	1:1035	Analog Input 3 HiHi
1:0010	Redundant Speed Loss Trip	1:1036	Analog Input 3 Hi
1:0011	Speed Fail Trip	1:1037	Analog Input 3 Lo
1:0012	Speed Fail Timeout Trip	1:1038	Analog Input 3 LoLo
1:0013	Resettable Trip Input Trip	1:1039	Analog In 3 Range Err
1:0014 to 38	User Configurable Trips 1 to 25	1:1040	Discrete Input 3
1:0101 to 134	Trip Latch First Out Registers 1-34	1:1041	Analog Input 4 HiHi
1:0201	Internal Fault Alarm	1:1042	Analog Input 4 Hi
1:0202	Power Supply 1 Fault Alarm	1:1043	Analog Input 4 Lo
1:0203	Power Supply 2 Fault Alarm	1:1044	Analog Input 4 LoLo
1:0204	Speed Fail Alarm	1:1045	Analog In 4 Range Err
1:0205	Speed Probe 1 Open Wire Alarm	1:1046	Discrete Input 4
1:0206	Speed Probe 2 Open Wire Alarm	1:1047	Analog Input 5 HiHi
1:0207	Speed Input 1 Lost Alarm	1:1048	Analog Input 5 Hi
1:0208	Speed Input 2 Lost Alarm	1:1049	Analog Input 5 Lo
1:0209	Redundant Speed Loss Alarm	1:1050	Analog Input 5 LoLo
1:0210	Speed Difference Alarm	1:1051	Analog In 5 Range Err
1:0211	Temp Overspeed SP is Active Alarm	1:1052	Discrete Input 5
1:0212	Simulated Speed Test in Progress Alarm	1:1053	Analog Input 6 HiHi
1:0213	Auto Speed Test Active Alarm	1:1054	Analog Input 6 Hi
1:0214	User Test 1 Active Alarm	1:1055	Analog Input 6 Lo
1:0215	User Test 2 Active Alarm	1:1056	Analog Input 6 LoLo
1:0216	User Test 3 Active Alarm	1:1057	Analog In 6 Range Err
1:0217	Trip Cycle Time Mon 1 Alarm	1:1058	Discrete Input 6
1:0218	Trip Cycle Time Mon 2 Alarm	1:1059	Reserved (Do not use)
1:0219 to 268	User Configurable Alarms 1 to 50	1:1060	Analog Input 7 Hi
1:0401 to 425	Event 1 Latched Inputs 1 to 25	1:1061	Analog Input 7 Lo
1:0501 to 525	Event 1 Latch First Outs 1 to 25	1:1062	Analog Input 7 LoLo
1:0601 to 625	Event 2 Latched Inputs 1 to 25	1:1063	Analog In 7 Range Err
1:0701 to 625	Event 2 Latch First Outs 1 to 25	1:1064	Discrete Input 7
1:0801 to 825	Event 3 Latched Inputs 1 to 25	1:1065	Reserved (Do not use)
1:0901 to 925	Event 3 Latch First Outs 1 to 25	1:1066	Reserved (Do not use)
1:1001	Speed Fail Override	1:1067	Reserved (Do not use)
1:1002	Overspeed Trip Non-Latched	1:1068	Reserved (Do not use)
1:1003	Overacceleration Trip Non-Latched	1:1069	Reserved (Do not use)
1:1004	Speed Fail Trip Non-Latched	1:1070	Reserved (Do not use)
1:1005	Reserved (Do not use)	1:1071	Reserved (Do not use)
1:1006	Speed Lost Alarm Non-Latched	1:1072	Reserved (Do not use)
1:1007	Speed Lost Trip Non-Latched	1:1073	Reserved (Do not use)
1:1008	Reserved (Do not use)	1:1074	Reserved (Do not use)
1:1009	Tmp Ovrsprd Setpoint On	1:1075	Reserved (Do not use)
1:1010	Simulated Speed Active	1:1076	Reserved (Do not use)
1:1011	Auto Test Speed Active	1:1077	Reserved (Do not use)
1:1012	Reserved (Do not use)	1:1078	Reserved (Do not use)
1:1013	User Defined Test 1	1:1079	Reserved (Do not use)
1:1014	User Defined Test 2	1:1080	Reserved (Do not use)
1:1015	User Defined Test 3	1:1081	Reserved (Do not use)
1:1016	Reserved (Do not use)	1:1082	Reserved (Do not use)
1:1017	Speed Fail Alarm Non-Latched	1:1083	Analog Comparator 1
1:1018	Trip	1:1084	Analog Comparator 2
1:1019	Alarm	1:1085	Analog Comparator 3
1:1020	Event Latch 1	1:1086	Analog Comparator 4
1:1021	Event Latch 2	1:1087	Analog Comparator 5
1:1022	Event Latch 3	1:1088	Analog Comparator 6
1:1023	Analog Input 1 HiHi	1:1089	Analog Comparator 7
1:1024	Analog Input 1 Hi	1:1090	Analog Comparator 8
1:1025	Analog Input 1 Lo	1:1091	Analog Comparator 9
1:1026	Analog Input 1 LoLo	1:1092	Analog Comparator 10

Table 4-4 (continued). Boolean Read Addresses (Code 02)

ADDRESS	DESCRIPTION	ADDRESS	DESCRIPTION
1:1093	Logic Gate 1	1:1160	Delay 8
1:1094	Logic Gate 2	1:1161	Delay 9
1:1095	Logic Gate 3	1:1162	Delay 10
1:1096	Logic Gate 4	1:1163	Delay 11
1:1097	Logic Gate 5	1:1164	Delay 12
1:1098	Logic Gate 6	1:1165	Delay 13
1:1099	Logic Gate 7	1:1166	Delay 14
1:1100	Logic Gate 8	1:1167	Delay 15
1:1101	Logic Gate 9	1:1168	Timer 1 HiHi
1:1102	Logic Gate 10	1:1169	Timer 1 Hi
1:1103	Logic Gate 11	1:1170	Timer 2 HiHi
1:1104	Logic Gate 12	1:1171	Timer 2 Hi
1:1105	Logic Gate 13	1:1172	Timer 3 HiHi
1:1106	Logic Gate 14	1:1173	Timer 3 Hi
1:1107	Logic Gate 15	1:1174	Timer 4 HiHi
1:1108	Logic Gate 16	1:1175	Timer 4 Hi
1:1109	Logic Gate 17	1:1176	Timer 5 HiHi
1:1110	Logic Gate 18	1:1177	Timer 5 Hi
1:1111	Logic Gate 19	1:1178	Timer 6 HiHi
1:1112	Logic Gate 20	1:1179	Timer 6 Hi
1:1113	Logic Gate 21	1:1180	Timer 7 HiHi
1:1114	Logic Gate 22	1:1181	Timer 7 Hi
1:1115	Logic Gate 23	1:1182	Timer 8 HiHi
1:1116	Logic Gate 24	1:1183	Timer 8 Hi
1:1117	Logic Gate 25	1:1184	Timer 9 HiHi
1:1118	Logic Gate 26	1:1185	Timer 9 Hi
1:1119	Logic Gate 27	1:1186	Timer 10 HiHi
1:1120	Logic Gate 28	1:1187	Timer 10 Hi
1:1121	Logic Gate 29	1:1188	Timer 11 HiHi
1:1122	Logic Gate 30	1:1189	Timer 11 Hi
1:1123	Logic Gate 31	1:1190	Timer 12 HiHi
1:1124	Logic Gate 32	1:1191	Timer 12 Hi
1:1125	Logic Gate 33	1:1192	Timer 13 HiHi
1:1126	Logic Gate 34	1:1193	Timer 13 Hi
1:1127	Logic Gate 35	1:1194	Timer 14 HiHi
1:1128	Logic Gate 36	1:1195	Timer 14 Hi
1:1129	Logic Gate 37	1:1196	Timer 15 HiHi
1:1130	Logic Gate 38	1:1197	Timer 15 Hi
1:1131	Logic Gate 39	1:1198	Unit Delay 1
1:1132	Logic Gate 40	1:1199	Unit Delay 2
1:1133	Logic Gate 41	1:1200	Unit Delay 3
1:1134	Logic Gate 42	1:1201	Unit Delay 4
1:1135	Logic Gate 43	1:1202	Unit Delay 5
1:1136	Logic Gate 44	1:1203	Unit Delay 6
1:1137	Logic Gate 45	1:1204	Unit Delay 7
1:1138	Logic Gate 46	1:1205	Unit Delay 8
1:1139	Logic Gate 47	1:1206	Unit Delay 9
1:1140	Logic Gate 48	1:1207	Unit Delay 10
1:1141	Logic Gate 49	1:1208	Reserved (Do not use)
1:1142	Logic Gate 50	1:1209	Reserved (Do not use)
1:1143	Latch 1	1:1210	Reserved (Do not use)
1:1144	Latch 2	1:1211	Internal Fault Trip Non-Latched
1:1145	Latch 3	1:1212	Internal Fault Alarm Non-Latched
1:1146	Latch 4	1:1213	Configuration Trip Non-Latched
1:1147	Latch 5	1:1214	Resettable Trip Non-Latched
1:1148	Latch 6	1:1215	Power Supply 1 Alarm Non-Latched
1:1149	Latch 7	1:1216	Power Supply 2 Alarm Non-Latched
1:1150	Latch 8	1:1217	Parameter Error Trip Non-Latched
1:1151	Latch 9	1:1218	Speed Input 2 Lost Alarm Non-Latched
1:1152	Latch 10	1:1219	Speed Input 2 Lost Trip Non-Latched
1:1153	Delay 1	1:1220	Speed Probe 1 Open Wire Alarm Non-Latched
1:1154	Delay 2	1:1221	Speed Probe 1 Open Wire Trip Non-Latched
1:1155	Delay 3	1:1222	Speed Probe 2 Open Wire Alarm Non-Latched
1:1156	Delay 4	1:1223	Speed Difference Alarm Non-Latched
1:1157	Delay 5	1:1224	Redundant Speed Loss Alarm Non-Latched
1:1158	Delay 6	1:1225	Redundant Speed Loss Trip Non-Latched
1:1159	Delay 7	1:1301	Heartbeat

Table 4-5. Analog Read Addresses (Code 04)

ADDRESS	DESCRIPTION	UNITS	RANGE
3:0001	Speed	RPM	0-500000
3:0002	Acceleration	RPM/Sec	-32768 - 32767
3:0003	Speed Channel 1	RPM	0-500000
3:0004	Speed Channel 2	RPM	0-500000
3:0101	Analog Input 1	mA x 100	0-2400
3:0102	Analog Input 2	mA x 100	0-2400
3:0103	Analog Input 3	mA x 100	0-2400
3:0104	Analog Input 4	mA x 100	0-2400
3:0105	Analog Input 5	mA x 100	0-2400
3:0106	Analog Input 6	mA x 100	0-2400
3:0107	Analog Input 7	mA x 100	0-2400
3:0201	Trip Cycle Time 1	milliseconds	0-65535
3:0202	Trip Cycle Time 2	milliseconds	0-65535
3:0301	Test Mode Time Remaining	seconds	0-65535
3:0401	Speed Fail Time Remaining	seconds	0-65535
3:0501	Timer 1 Seconds Value	seconds	0-65535
3:0502	Timer 1 Milliseconds Value	milliseconds	0-999
3:0503	Timer 2 Seconds Value	seconds	0-65535
3:0504	Timer 2 Milliseconds Value	milliseconds	0-999
3:0505	Timer 3 Seconds Value	seconds	0-65535
3:0506	Timer 3 Milliseconds Value	milliseconds	0-999
3:0507	Timer 4 Seconds Value	seconds	0-65535
3:0508	Timer 4 Milliseconds Value	milliseconds	0-999
3:0509	Timer 5 Seconds Value	seconds	0-65535
3:0510	Timer 5 Milliseconds Value	milliseconds	0-999
3:0511	Timer 6 Seconds Value	seconds	0-65535
3:0512	Timer 6 Milliseconds Value	milliseconds	0-999
3:0513	Timer 7 Seconds Value	seconds	0-65535
3:0514	Timer 7 Milliseconds Value	milliseconds	0-999
3:0515	Timer 8 Seconds Value	seconds	0-65535
3:0516	Timer 8 Milliseconds Value	milliseconds	0-999
3:0517	Timer 9 Seconds Value	seconds	0-65535
3:0518	Timer 9 Milliseconds Value	milliseconds	0-999
3:0519	Timer 10 Seconds Value	seconds	0-65535
3:0520	Timer 10 Milliseconds Value	milliseconds	0-999
3:0521	Timer 11 Seconds Value	seconds	0-65535
3:0522	Timer 11 Milliseconds Value	milliseconds	0-999
3:0523	Timer 12 Seconds Value	seconds	0-65535
3:0524	Timer 12 Milliseconds Value	milliseconds	0-999
3:0525	Timer 13 Seconds Value	seconds	0-65535
3:0526	Timer 13 Milliseconds Value	milliseconds	0-999
3:0527	Timer 14 Seconds Value	seconds	0-65535
3:0528	Timer 14 Milliseconds Value	milliseconds	0-999
3:0529	Timer 15 Seconds Value	seconds	0-65535
3:0530	Timer 15 Milliseconds Value	milliseconds	0-999
3:0601	Temp Overspeed SetPoint	RPM	0-65535
3:0602	Simulated Speed RPM	RPM	0-65535
3:0701	Last Trip Month	Months	1-12
3:0702	Last Trip Day	Days	1-31
3:0703	Last Trip Year	Years	2000-2099
3:0704	Last Trip Hour	Hours	0-23
3:0705	Last Trip Minute	Minutes	0-59
3:0706	Last Trip Second	seconds	0-59

3:0707	Last Trip Milli-Second	milliseconds	0-999
3:0801	Unit Health Status	Enum	0-2

Chapter 5. Troubleshooting

Many troubleshooting features are available from the front panel. In general, the following high level approach can be used to troubleshoot the ProTech-SX control.

1. Check the front panel LEDs
2. View the trip and alarm logs by pressing the corresponding view buttons on the front panel
3. Use the messages in the trip and alarm logs to assist in troubleshooting. The messages are summarized in the tables below.
4. Use the Monitor Menu from the front panel to trace and branch to potential I/O, configuration, and programming problems.
5. For more in depth help, use the service tool provided with the ProTech-SX.

The entry point for troubleshooting the ProTech-SX is the state of the three LEDs on lower part of the front panel. The Trip Log and the Alarm Log can also be viewed from the front panel. The service tool also provides more detailed information in the log pages.

UNIT HEALTH LED

The UNIT HEALTH LED indicates module health status.

Green – Unit OK and functioning properly.

Red – Safety Functionality is not running/internal fault trip is present.

Unlit – Status unknown because of a communication fault with the front panel or the module is not powered.

TRIPPED LED

The TRIPPED LED indicates the state of the trip latch.

Unlit - Unit not tripped or the module is not powered.

Red – unit tripped, press VIEW button below the LED to see the trip log log or navigate to the Monitor Trip Latch screen to see the active status on each trip input.

ALARM LED

The ALARM LED indicates the state of the alarm latch.

- Unlit – no alarms or the module is not powered.
- Yellow – active alarms, press VIEW button below LED to see the alarm log or navigate to the Monitor Alarm Latch screen to see the active status on each alarm input.

I/O Troubleshooting

Problem or Diagnostic Indication	Possible Cause	Suggested Actions
Power Supply Inputs not working properly. Power supply input alarm present.	Wiring fault, terminal block loose.	Verify wiring and terminal block connections.
	Power source breaker or fuse open.	Verify breaker or fuse.
	Only one power supply is connected.	On the front panel, press the VIEW button under the ALARM LED and check for Power Supply 1 or 2 Fault.
	Power supply input out of range or insufficient rating.	Remove the field connections and check input voltage level and verify it is within acceptable range per electrical specifications. Also check that power supply has appropriate rating to power the ProTech-SX.
Speed Input not working	Wiring fault, terminal block loose.	Verify wiring and terminal block connections.
	Configuration	On the front panel, check the Configure Speed Manager and Configure Speed Inputs Menu and verify that all proper configuration options are selected.
	Alarms and Faults	Verify that there are no alarms or faults that may indicate a setup problem (open wire conditions, speed lost, speed fail, etc.)
	Signal level	Verify that the input signal levels are within the electrical specifications. Also verify shield connections.
	Active Probe Power	If using an active probe for speed input 1, verify probe power is correct by disconnecting the probe and measuring from terminals 69 to 71. The voltage should be 24 V \pm 10%. Attach probe and measure again to verify that the probe is not overloading the voltage provided by the ProTech-SX.
		NOTE: Only speed input 1 supports active probes! Speed input 2 only supports passive probes.

Problem or Diagnostic Indication	Possible Cause	Suggested Actions
Dedicated discrete input not working (Start, Reset or Speed Fail Override)	Wiring fault, terminal block loose.	Verify wiring and terminal block connections.
	Configuration	On the front panel, check the Dedicated Discrete Inputs Monitor Menu and verify logic state is correct.
	Signal source not working correctly or not within acceptable electrical specifications.	Check signal level and verify it is within acceptable range per electrical specifications.
Configurable Input - Discrete input not working	Internally supplied wetting voltage fault.	Measure voltage from terminal 1 to terminal 81 and verify it is 23 V \pm 2 V. If out of range, return unit to Woodward.
	Wiring fault, terminal block loose.	Verify wiring and terminal block connections.
	Configuration	On the front panel, check the Configurable Inputs Monitor Menu and verify logic state is correct. Using the PCT, verify that the input is configured as discrete input.
Configurable Input – Analog Input not working	Signal source not working correctly or not within acceptable electrical specifications.	Check signal level and verify it is within acceptable range per electrical specifications.
	Internally supplied wetting voltage fault.	Measure voltage from terminal 37 to terminal 38 and verify it is 24 V \pm 10%. If out of range, remove wiring and measure again to verify that the voltage source is not being overloaded..
	Wiring fault, terminal block loose.	Verify wiring and terminal block connections.
Configurable Input – Analog Input not working	Configuration	On the front panel, check the Configurable Inputs Monitor Menu and verify the correct analog input level is displayed. A “signal out of range” indicates the input is less than 2 mA or greater than 22 mA. Using the PCT, verify that the input is configured as analog input and the Lo, LoLo, Hi, HiHi limits are set correctly..
	Signal source not working correctly or not within acceptable electrical specifications.	Check signal level and verify it is within acceptable range per electrical specifications. Verify shield connection.

Problem or Diagnostic Indication	Possible Cause	Suggested Actions
Trip relays not working	Wiring fault, terminal block loose.	Verify wiring and terminal block connections.
	Configuration	Using the service tool or front panel, check to see that the trip configuration is set correctly. Energize to trip vs. de-energize to trip will invert the polarity on the relays.
	External supplies	Check the power supplies that provide voltage to the relay output. If using the 24 V EXT available from the ProTech-SX, measure voltage between terminals 80, 81 and verify 24 V \pm 10%. If it is not, remove the wiring from the 24 V EXT to unload the output and measure again to verify the voltage is not being overloaded.
Programmable relay output not working	Wiring fault, terminal block loose.	Verify wiring and terminal block connections.
	Configuration	Using the PCT, check to see that the polarity is set correctly and the correct internal signal is selected to drive the output.
	External supplies	Check the power supplies that provide voltage to the relay output. If using the 24 V EXT available from the ProTech-SX, measure voltage between terminals 80, 81 and verify 24 V \pm 10%. If it is not, remove the wiring from the 24 V EXT to unload the output and measure again to verify the voltage is not being overloaded.
Analog Output not working	Wiring fault, terminal block loose.	Verify wiring and terminal block connections.
		On the front panel, check the Monitor Analog Output Menu and verify that the analog output is reading an expected output value.
	Configuration	Measure the current from terminal 64 and verify that it corresponds to the previous step.
Verify the load on the analog output is within the electrical specifications.		
	Configuration	Using the PCT or front panel, verify that the scaling is correct.

Problem or Diagnostic Indication	Possible Cause	Suggested Actions
MODBUS not working	Wiring fault, terminal block loose.	Verify wiring and terminal block connections. In particular, verify that the HI and LO wires are terminated to the correct terminals for RS-485 and the likewise for TXD and RXD for RS-232. Also verify the terminations jumpers are installed for RS-485 mode
	Configuration	Using the PCT or front panel, verify that the correct settings are selected.
Service Tool not working	Wiring and connection	Verify cable that is plugged into DB9 port is not a crossover. A straight-through cable is required.
	COM Port	<p>Check that there is power applied to the ProTech-SX module that the service tool is connected.</p> <p>Verify the correct COM port is selected when establishing communications and that Auto Detection BAUD rate is selected.</p>

Trip Indications

Problem or Diagnostic Indication	Description	Possible Cause	Suggested Actions
Unit Health LED is RED (Internal Fault trip)	The module tripped on an internal fault	Various	<p>Connect the PCT and view the Module Faults Log. This log expands the Internal Fault annunciation.</p> <p>Recycle power to the module and see if LED returns to GREEN after initialization.</p> <p>In general, it is not possible to fix internal faults without returning the unit to Woodward.</p>
Power Up Trip	The module has lost power and has been restored.	Power source fault or breaker reset.	Verify power source, breaker, fuse and wiring integrity. The Reset function will reset the module.
Configuration Trip	Trip is issued internally to keep the module in tripped state while the module is actively saving a configuration.	The module is actively saving a configuration.	Wait for module to finish saving configuration. Reset function will reset the module.
Parameter Error	An error has been detected in the internally stored parameters. Internally stored parameters are constantly checked for data integrity.	Non-volatile memory hardware fault or internal fault.	<p>Reload configuration settings using the PCT. Cycle input power.</p> <p>If Parameter Error persists return unit to Woodward according to the instructions in Chapter 8 of this manual.</p>
Overspeed Trip	The module tripped on an overspeed event.	<p>Turbine overspeed</p> <p>Configuration</p>	<p>Check trip system prior to operating turbine, including ProTech-SX built-in simulated speed tests to verify ProTech-SX functionality.</p> <p>Using the PCT or front panel, verify that the correct settings are selected.</p>

Problem or Diagnostic Indication	Description	Possible Cause	Suggested Actions
Overacceleration Trip	The module tripped on an overacceleration event.	Rapid turbine acceleration Configuration	Check trip system prior to operating turbine, including ProTech-SX built-in simulated speed tests to verify ProTech-SX functionality. Using the PCT or front panel, verify that the correct settings are selected.
Spd 1 Open Wire Trip	The module's speed redundancy mode is configured as 'Single Speed' and it has detected an open wire condition on the speed probe connected to speed input 1. (Passive, or MPU probe only)	Wiring fault or probe fault.	Check wiring continuity and probe integrity.
Speed 1 Lost Trip Speed 2 Lost Trip	Sudden Speed Loss is configured as Trip and the module has detected a sudden speed loss on speed input 1 or speed input 2 respectively.	Wiring fault or probe fault.	Check wiring continuity and probe integrity.
Redundant Speed Loss Trip	Speed Redundancy Mode is configured as Dual Redundant Speed, Redundant Speed Loss is configured as Trip and both speed inputs are lost.	On both speed inputs either one of the following conditions is present: Speed Lost Trip or Speed Probe Open Wire condition	See respective sections for Speed Loss or Speed Probe Open Wire conditions in this troubleshooting section for details.
Speed Fail Trip	Start logic – Speed Fail Trip is enabled and the module has detected the Speed Fail Override contact input is open while speed is below the user configured Speed Fail Setpoint.	Wiring fault, speed probe fault Speed Fail Override contact input operation not correct. Incorrect speed fail setpoint configured,	Check wiring continuity and probe integrity. Check contact and wiring operation. See manual for description of function. Use PCT to verify proper configuration settings.

Problem or Diagnostic Indication	Description	Possible Cause	Suggested Actions
Speed Fail Timeout	Start logic - the module has not detected speed within the time set by the Speed Fail Timeout setting.	Wiring fault, speed probe fault Incorrect speed fail timeout time configured	Check wiring continuity and probe integrity. See manual for description of function. Use PCT to verify proper configuration settings.

Alarm Indications

Problem or Diagnostic Indication	Description	Possible Cause	Suggested Actions
Internal Fault Alarm	The module has an internal fault that is annunciated an alarm and not a trip.	Various	Connect the service tool and view the Trip And Alarm Log. This log expands the Internal Fault Alarm annunciation.
Power Supply 1 Fault	The module has detected a fault on Power Supply 1.	Power supply input 1 is either faulted or the power is disconnected.	Check the power source, breaker, fuse and connections. Note the module will continue to operate normally on power supply 2.
Power Supply 2 Fault	The module has detected a fault on Power Supply 2.	Power supply input 2 is either faulted or the power is disconnected.	Check the power source, breaker, fuse and connections. Note the module will continue to operate normally on power supply 1.
Speed Fail Alarm	Start logic – Speed Fail Alarm is enabled and the module has detected the Speed Fail Override contact input is open while speed is below the user configured Speed Fail Setpoint.	Wiring fault, speed probe fault Speed Fail Override contact input operation not correct. Incorrect speed fail setpoint configured,	Check wiring continuity and probe integrity. Check contact and wiring operation. See manual for description of function. Use PCT or front panel to verify proper configuration settings.
Speed 1 Lost Alarm	Sudden Speed Loss is configured as Alarm and the module has detected a sudden speed loss on speed input 1.	Wiring fault or probe fault.	Check wiring continuity and probe integrity.
Speed 2 Lost Alarm	Sudden Speed Loss is configured as Alarm and the module has detected a sudden speed loss on speed input 2.	Wiring fault or probe fault.	Check wiring continuity and probe integrity.

Problem or Diagnostic Indication	Description	Possible Cause	Suggested Actions
Spd 1 Probe Open Wire Alarm	The module's speed redundancy mode is configured as 'Dual Redundant Speed' and it has detected an open wire condition on the speed probe connected to speed input 1 (Passive, or MPU probe only).	Wiring fault or probe fault.	Check wiring continuity and probe integrity.
Spd 2 Probe Open Wire Alarm	The module's speed redundancy mode is configured as 'Dual Redundant Speed' and it has detected an open wire condition on the speed probe connected to speed input 2.	Wiring fault or probe fault.	Check wiring continuity and probe integrity.
Redundant Speed Loss Alarm	Speed Redundancy Mode is configured as Dual Redundant Speed, Redundant Speed Loss is configured as Alarm and both speed inputs are lost.	On both speed inputs either one of the following conditions is present: Speed Lost Alarm or Speed Probe Open Wire condition	See respective sections for Speed Loss or Speed Probe Open Wire conditions in this troubleshooting section for details.
Speed Difference Alarm	Speed Redundancy Mode is configured as Dual Redundant Speed and difference between speed input 1 and speed input 2 is greater than configured threshold.	Difference between speed input 1 and speed input 2 is greater than configured threshold for more than 2 seconds.	Check wiring continuity and probe integrity. See manual for description of function. Use PCT to verify proper configuration settings.
Tmp Overspd Setpoint On	Indicates the temporary overspeed setpoint has been activated.	User initiated temporary setpoint test.	See manual for description and limitations. Use PCT or front panel to verify settings.
Manual Sim. Speed Test	Indicates the manual simulated overspeed test has been activated.	User initiated simulated speed test.	See manual for description and limitations.
Auto Sim. Speed Test	Indicates the automated simulated overspeed test has been activated.	User initiated simulated speed test.	See manual for description and limitations.
User Defined Test 1	Indicates the User Defined Test 1 has been activated	User enabled the User Defined Test or the configured Set Input was true.	Connect PCT and verify settings. Check the set and reset functions are correct. Note specifically the effect of the timeout setting.

Problem or Diagnostic Indication	Description	Possible Cause	Suggested Actions
User Defined Test 2	Indicates the User Defined Test 2 has been activated	User enabled the User Defined Test or the configured Set Input was true.	Connect PCT and verify settings. Check the set and reset functions are correct. Note specifically the effect of the timeout setting.
User Defined Test 3	Indicates the User Defined Test 3 has been activated	User enabled the User Defined Test or the configured Set Input was true.	Connect PCT and verify settings. Check the set and reset functions are correct. Note specifically the effect of the timeout setting.
Trip Cycle Time Mon 1 Alarm	Indicates the Trip Cycle Monitor Time 1 Alarm has been set.	Trip Cycle Monitor Time 1 Alarm is set when the maximum cycle time has been exceeded during a trip cycle time test.	<p>Check the Trip Cycle Time Monitor Menu and note the trip cycle time to see if the cycle time indicator signal is reaching the ProTech-SX.</p> <p>Connect PCT and verify settings. Verify the trip indicator input is from the correct source and the max cycle time setting is correct.</p> <p>Check external system by following the trip signal around the loop until it returns back to the ProTech-SX input that is designated as the trip indicator input.</p>
Trip Cycle Time Mon 2 Alarm	Indicates the Trip Cycle Monitor Time 2 Alarm has been set.	Trip Cycle Monitor Time 2 Alarm is set when the maximum cycle time has been exceeded during a trip cycle time test.	<p>Check the Trip Cycle Time Monitor Menu and note the trip cycle time to see if the cycle time indicator signal is reaching the ProTech-SX.</p> <p>Connect PCT and verify settings. Verify the trip indicator input is from the correct source and the max cycle time setting is correct.</p> <p>Check external system by following the trip signal around the loop until it returns back to the ProTech-SX input that is designated as the trip indicator input.</p>

Chapter 6. Safety Management

Product Variations Certified

The functional safety requirement in this manual applies to all the ProTech-SX variations.

These products are certified for use in applications up to SIL2 according to IEC61508.

Safe State

The ProTech-SX is designed so that the safe state can be configured for either de-energize or energize to trip. De-energize to trip will place trip relays into their unpowered, normally open state.

The de-energize-to-trip functionality is implemented such that a complete loss of power to the module results in a trip of that module. The energize-to-trip functionality is implemented such that a complete loss of power to the module does not result in a trip of that module.

When configured as de-energize-to-trip, the module powers up in the tripped state. When configured as energize-to-trip, the module powers up such that it does not enter the tripped state unless a trip condition is present.

Table 6-1. Initial Power-up States

Configuration	Module Power Loss State	Module Power Up State
De-energize to trip	Tripped	Tripped
Energize to trip	Not Tripped	Not Tripped, unless trip condition present.

SIL Specifications

Probability of Failure on Demand (PFD) and Probability of dangerous Failure per Hour (PFH) calculations have been performed on the ProTech-SX according to IEC61508. For SIL3, IEC states the following requirements.

Table 6-2. SIL 2 Values

Type	SIL 2 Value
PFH	10^{-7} to 10^{-6}
PFD	10^{-3} to 10^{-2}
SFF	> 90%

The ProTech-SX meets SIL2 with the following numbers:

PFH	
2.8E-7 1/h	
PFD	
PFD	Proof Test Interval
1.2E-3	6 month
1.9E-3	9 month
2.5E-3	1year
Safe Failure Fraction	
SFF > 90%	

Diagnostic Coverage

DC > 90%

Failure Rate Data

The Mean Time to Failure (MTTF) is a measure of time between failures that cause a complete process shutdown. In determining this number, IEC61508 evaluation takes into account safe failure and dangerous detected failures that cause a module trip.

Table 6-3. Failure Rate Data

MTTF

> 54000 years

Response Time Data

The response time for a safety system must be less than the process safety time. The system integrator must determine the process safety time and the response time of all elements (sensors, ProTech-SX, actuators, etc.) that make up the total process safety time. For this purpose, the ProTech-SX response time is given below.

Table 6-4. Response Time Data

Response Time

Independent Trip Relay Versions

< 12 ms

The response time of the ProTech-SX is the time from when a signal is received at the ProTech-SX terminal blocks that is out of a range as defined by the programming (i.e. speed, analog input) to the point where the trip relays have changed state.

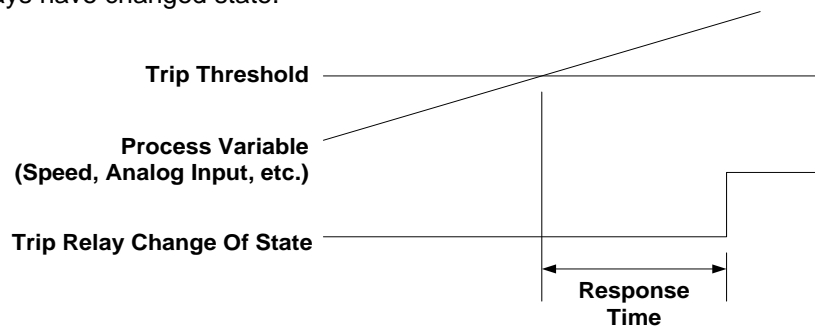

Figure 6-1. Trip Response Time

Limitations

When proper installation, maintenance, proof testing, and environmental limitations are observed, the product life of the ProTech-SX is 20 years.

Management of Functional Safety

The ProTech-SX is intended for use according to the requirements of a safety lifecycle management process such as IEC61508 or IEC61511. The safety performance numbers in this chapter can be used for the evaluation of the overall safety lifecycle.

Restrictions

The user must complete a full functional check of the ProTech-SX after initial installation and after any modification of the programming or configuration of the device. This functional check should include as much of the safety system as possible, such as sensors, transmitters, actuators, and trip blocks. The ProTech-SX has programming capability to facilitate the automatic checkout and periodic maintenance of the safety system. For help on programming, see the chapters on functionality, configuration, and the example applications.

The ProTech-SX must be used within the published specification in this manual.

Competence of Personnel

All persons involved in the initial design or modification of the programmable software, installation and maintenance must have appropriate training. Training and guidance materials include this manual, the ProTech-SX service tool, and training programs available at Woodward. See Chapter 8 (Service Options) for more information.

Operation and Maintenance Practice

A periodic proof (functional) test of the ProTech-SX is required to verify that no dangerous faults not detected by internal run-time diagnostics remain undetected. More information is in the “Proof Test” section of this chapter. The frequency of the proof test is determined by the overall safety system design, of which the ProTech-SX is part of the safety system. The safety numbers are given in the following sections to help the system integrator determine the appropriate test interval. This will require password access to the front panel menus.

Installation and Site Acceptance Testing

Installation and use of the ProTech-SX must conform to the guidelines and restrictions included in this manual. No other information is needed for installation, programming, and maintenance. This will require password access to the front panel menus.

Functional Testing after Initial Installation

A functional test of the ProTech-SX is required prior to use as a safety system. This should be done as part of the overall safety system installation check and should include all I/O interfaces to and from the ProTech-SX that are part of the safety system. For guidance on the functional test, see the proof test procedure below. This will require password access to the front panel menus.

Functional Testing after Changes

A functional test of the ProTech-SX is required after making any changes that affect the safety system. Although there are functions in the ProTech-SX that are not directly safety related, it is recommended that a functional test is performed after any change. This will require password access to the front panel menus.

Proof Testing (Functional Test)

The ProTech-SX must be periodically proof tested to ensure there are no dangerous faults present that are not detected by on-line diagnostics. Many built-in test modes are included. The test procedure will set the trip outputs on the module under test into a trip state (de-energized for a de-energize-to-trip configuration and energized in an energized to trip configuration). It is possible to automate several steps of the proof test procedure shown below using the programmability and test mode configurability of the ProTech-SX, but the intent of the steps below must be met.

With the procedure below, the user can expect 99% test coverage of the dangerous failures that are not tested by online diagnostics.

Functional Verification (Proof) Test Procedure:

This procedure requires a digital multimeter for resistance and voltage measurement. This procedure will require password access to the front panel menus.

1. Cycle Power on the module and verify there are no internal faults on the Alarm Latch page of the monitor menu.
2. Remove power from one power supply input (power supply input 1 or 2) at a time and verify the correct fault is read on the Alarm Latch page of the monitor menu.
3. Measure external 24 V EXT (terminals 80 – 81; 23 ± 1 V).
4. Verify proper Discrete Input voltage (terminals 37 – 38; 23 ± 1 V).
5. Measure SPEED PWR (terminals 69 – 71). Insure active probe mode is selected in Speed Configuration Menu, make the measurement, and insure probe type is in original configuration (23 ± 1 V).
6. Test Speed input by using one of the internal speed test modes in the Test Menu. Resistance measurement of each of the outputs is required. Verify as follows:
 - a. With module not tripped, resistance measurement from 1A – 1B, or 2A – 2B must be less than 100Ω .
 - b. With module tripped, resistance measurement from 1A – 1B, or 2A – 2B must be greater than $1 M\Omega$.
7. Test any configurable inputs that are set to analog mode to make sure that all inputs are operational. The analog signal must be varied from a steady state value. Verify the proper signal by monitoring the respective input on the Monitor Menu\Configurable Input page of the front panel.
8. Test any configurable inputs that are set to discrete mode to make sure that all inputs are operational and not stuck in the ON or OFF state. Inputs must be cycled from ON to OFF and OFF to ON. Verify the proper signal by monitoring the respective input on the Monitor Menu\Configurable Input page of the front panel.
9. Test Programmable Outputs if used as part of the safety system.
10. Cycle dedicated inputs and verify the proper signal by monitoring the respective input on the Monitor Menu/Dedicated Discrete Input page of the front panel.
11. If possible, compare external speed with measured speed reading on the ProTech-SX display.
12. If used as part of the safety system, verify the analog output. Measure this output by performing an automated overspeed trip test as described in step 6.
13. Chassis isolation checks using resistance measurement. Measure from terminals 39, 57, 63, 68 to a point on the ProTech-SX chassis (the grounding braid is a good place for this measurement): $< 1 \Omega$.
14. Perform a lamp test from front panel Test Menu.

Chapter 7. Asset Management

Product Storage Recommendations

The unit may be stored in its original shipping container until it is ready for installation. Protect the device from weather and from extreme humidity or temperature fluctuations during storage. This product is designed for continuous storage in IP56 rated locations with an ambient temperature range of: –20 to +65 °C.

To ensure product shelf life, Woodward recommends that a stored ProTech-SX be powered up (power source applied to each module) for 5 minutes every 24–36 months. This procedure re-establishes an electrical charge into the product's electrolytic capacitors, extending their shelf life. (See the Unpacking section in the chapter on Installation for unpacking.)

Refurbishment Period Recommendation

This product is designed for continuous operation in a typical industrial environment and includes no components that require periodic service. However, to take advantage of related product software and hardware improvements, Woodward recommends that your product be sent back to Woodward or to a Woodward authorized service facility after every five to ten years of continuous service for inspection and component upgrades. Please refer to the service programs in the following chapter.

**WARNING****EXPLOSION HAZARD—Substitution of components may impair suitability for Class I, Division 2.**

Chapter 8.

Product Support and Service Options

Product Support Options

If you are experiencing problems with the installation, or unsatisfactory performance of a Woodward product, the following options are available:

- Consult the troubleshooting guide in the manual.
- Contact the manufacturer or packager of your system.
- Contact the Woodward Full Service Distributor serving your area.
- Contact Woodward technical assistance (see “How to Contact Woodward” later in this chapter) and discuss your problem. In many cases, your problem can be resolved over the phone. If not, you can select which course of action to pursue based on the available services listed in this chapter.

OEM or Packager Support: Many Woodward controls and control devices are installed into the equipment system and programmed by an Original Equipment Manufacturer (OEM) or Equipment Packager at their factory. In some cases, the programming is password-protected by the OEM or packager, and they are the best source for product service and support. Warranty service for Woodward products shipped with an equipment system should also be handled through the OEM or Packager. Please review your equipment system documentation for details.

Woodward Business Partner Support: Woodward works with and supports a global network of independent business partners whose mission is to serve the users of Woodward controls, as described here:

- A **Full Service Distributor** has the primary responsibility for sales, service, system integration solutions, technical desk support, and aftermarket marketing of standard Woodward products within a specific geographic area and market segment.
- An **Authorized Independent Service Facility (AISF)** provides authorized service that includes repairs, repair parts, and warranty service on Woodward's behalf. Service (not new unit sales) is an AISF's primary mission.

A current list of Woodward Business Partners is available at www.woodward.com/local-partner

Product Service Options

The following factory options for servicing Woodward products are available through your local Full-Service Distributor or the OEM or Packager of the equipment system, based on the standard Woodward Product and Service Warranty (5-01-1205) that is in effect at the time the product is originally shipped from Woodward or a service is performed:

- Replacement/Exchange (24-hour service)
- Flat Rate Repair
- Flat Rate Remanufacture

Replacement/Exchange: Replacement/Exchange is a premium program designed for the user who is in need of immediate service. It allows you to request and receive a like-new replacement unit in minimum time (usually within 24 hours of the request), providing a suitable unit is available at the time of the request, thereby minimizing costly downtime. This is a flat-rate program and includes the full standard Woodward product warranty 5-01-1205 North American Terms and Conditions of Sale (Industrial Business Segment).

This option allows you to call your Full-Service Distributor in the event of an unexpected outage, or in advance of a scheduled outage, to request a replacement control unit. If the unit is available at the time of the call, it can usually be shipped out within 24 hours. You replace your field control unit with the like-new replacement and return the field unit to the Full-Service Distributor.

Charges for the Replacement/Exchange service are based on a flat rate plus shipping expenses. You are invoiced the flat rate replacement/exchange charge plus a core charge at the time the replacement unit is shipped. If the core (field unit) is returned within 60 days, a credit for the core charge will be issued.

Flat Rate Repair: Flat Rate Repair is available for the majority of standard products in the field. This program offers you repair service for your products with the advantage of knowing in advance what the cost will be. All repair work carries the standard Woodward service warranty 5-01-1205 North American Terms and Conditions of Sale (Industrial Business Segment) on replaced parts and labor.

Flat Rate Remanufacture: Flat Rate Remanufacture is very similar to the Flat Rate Repair option with the exception that the unit will be returned to you in "like-new" condition and carry with it the full standard Woodward product warranty 5-01-1205 North American Terms and Conditions of Sale (Industrial Business Segment). This option is applicable to mechanical products only.

Returning Equipment for Repair

If a control (or any part of an electronic control) is to be returned for repair, please contact your Full-Service Distributor in advance to obtain Return Authorization and shipping instructions.

When shipping the item(s), attach a tag with the following information:

- Return authorization number
- Name and location where the control is installed
- Name and phone number of contact person
- Complete Woodward part number(s) and serial number(s)
- Description of the problem
- Instructions describing the desired type of repair

Packing a Control

Use the following materials when returning a complete control:

- Protective caps on any connectors
- Antistatic protective bags on all electronic modules
- Packing materials that will not damage the surface of the unit
- At least 100 mm (4 inches) of tightly packed, industry-approved packing material
- A packing carton with double walls
- A strong tape around the outside of the carton for increased strength

NOTICE

To prevent damage to electronic components caused by improper handling, read and observe the precautions in Woodward manual 82715, *Guide for Handling and Protection of Electronic Controls, Printed Circuit Boards, and Modules*.

Replacement Parts

When ordering replacement parts for controls, include the following information:

- The part number(s) (XXXX-XXXX) that is on the enclosure nameplate
- The unit serial number, which is also on the nameplate

Engineering Services

Woodward offers various Engineering Services for our products. For these services, you can contact us by telephone, by email, or through the Woodward website.

- Technical Support
- Product Training
- Field Service

Technical Support is available from your equipment system supplier, your local Full-Service Distributor, or from many of Woodward's worldwide locations, depending upon the product and application. This service can assist you with technical questions or problem solving during the normal business hours of the Woodward location you contact. Emergency assistance is also available during non-business hours by phoning Woodward and stating the urgency of your problem.

Product Training is available as standard classes at many of our worldwide locations. We also offer customized classes, which can be tailored to your needs and can be held at one of our locations or at your site. This training, conducted by experienced personnel, will assure that you will be able to maintain system reliability and availability.

Field Service engineering on-site support is available, depending on the product and location, from many of our worldwide locations or from one of our Full-Service Distributors. The field engineers are experienced both on Woodward products as well as on much of the non-Woodward equipment with which our products interface.

For information on these services, please contact one of the Full-Service Distributors listed at www.woodward.com/local-partner.

Contacting Woodward's Support Organization

For the name of your nearest Woodward Full-Service Distributor or service facility, please consult our worldwide directory at <https://www.woodward.com/support>, which also contains the most current product support and contact information.

You can also contact the Woodward Customer Service Department at one of the following Woodward facilities to obtain the address and phone number of the nearest facility at which you can obtain information and service.

Products Used in Electrical Power Systems

<u>Facility</u>	<u>Phone Number</u>
Brazil	+55 (19) 3708 4800
China	+86 (512) 8818 5515
Germany	+49 (711) 78954-510
India	+91 (124) 4399500
Japan	+81 (43) 213-2191
Korea	+82 (32) 422-5551
Poland	+48 (12) 295 13 00
United States	+1 (970) 482-5811

Products Used in Engine Systems

<u>Facility</u>	<u>Phone Number</u>
Brazil	+55 (19) 3708 4800
China	+86 (512) 8818 5515
Germany	+49 (711) 78954-510
India	+91 (124) 4399500
Japan	+81 (43) 213-2191
Korea	+ 82 (32) 422-5551
The Netherlands	+31 (23) 5661111
United States	+1 (970) 482-5811

Products Used in Industrial Turbomachinery Systems

<u>Facility</u>	<u>Phone Number</u>
Brazil	+55 (19) 3708 4800
China	+86 (512) 8818 5515
India	+91 (124) 4399500
Japan	+81 (43) 213-2191
Korea	+ 82 (32) 422-5551
The Netherlands	+31 (23) 5661111
Poland	+48 (12) 295 13 00
United States	+1 (970) 482-5811

Technical Assistance

If you need to contact technical assistance, you will need to provide the following information. Please write it down here before contacting the Engine OEM, the Packager, a Woodward Business Partner, or the Woodward factory:

General

Your Name _____

Site Location _____

Phone Number _____

Fax Number _____

Prime Mover Information

Manufacturer _____

Turbine Model Number _____

Type of Fuel (gas, steam, etc.) _____

Power Output Rating _____

Application (power generation, marine,
etc.) _____

Control/Governor Information

Control/Governor #1

Woodward Part Number & Rev. Letter _____

Control Description or Governor Type _____

Serial Number _____

Control/Governor #2

Woodward Part Number & Rev. Letter _____

Control Description or Governor Type _____

Serial Number _____

Control/Governor #3

Woodward Part Number & Rev. Letter _____

Control Description or Governor Type _____

Serial Number _____

Symptoms

Description _____

If you have an electronic or programmable control, please have the adjustment setting positions or the menu settings written down and with you at the time of the call.

Appendix.

Modbus Ethernet Gateway Information

Introduction

For customers who want to use Modbus Ethernet communications or put the ProTech® on the plant network, Woodward recommends the following Ethernet-to-Serial Gateways:

1. B&B Electronics –
 Model: MESR901
 Serial: RS-232, RS-485, or RS-422
 Power Input: 10–48 VDC

B&B Electronics Mfg. Co.
 707 Dayton Road
 P.O. Box 1040
 Ottawa, IL 61350
 USA

Phone: (815) 433-5100 (8-5:00 CST, M-F)
 Email: orders@bb-elec.com
 Web: www.bb-elec.com



2. Lantronix –
 Model: UDS100-Xpress DR IAP
 Serial: RS-232, RS-485, or RS-422
 Power Input: 9–30 VDC, 9–24 VAC

Lantronix
 15353 Barranca Parkway
 Irvine, CA 92618
 USA

Phone: 1-800-422-7055
 Email: sales@lantronix.com
 Web: www.lantronix.com



B&B Electronics Setup

Below you will find the wiring setup and software configuration for the MESR901. Remember that the pictures below are for reference—you will need to set up the serial configuration to match the settings you chose in the ProTech. When multi-dropping the 3 modules together using RS-485/422, you will need to assign each module a unique node address, which can be found in the Modbus configuration screen on the ProTech.

Wiring

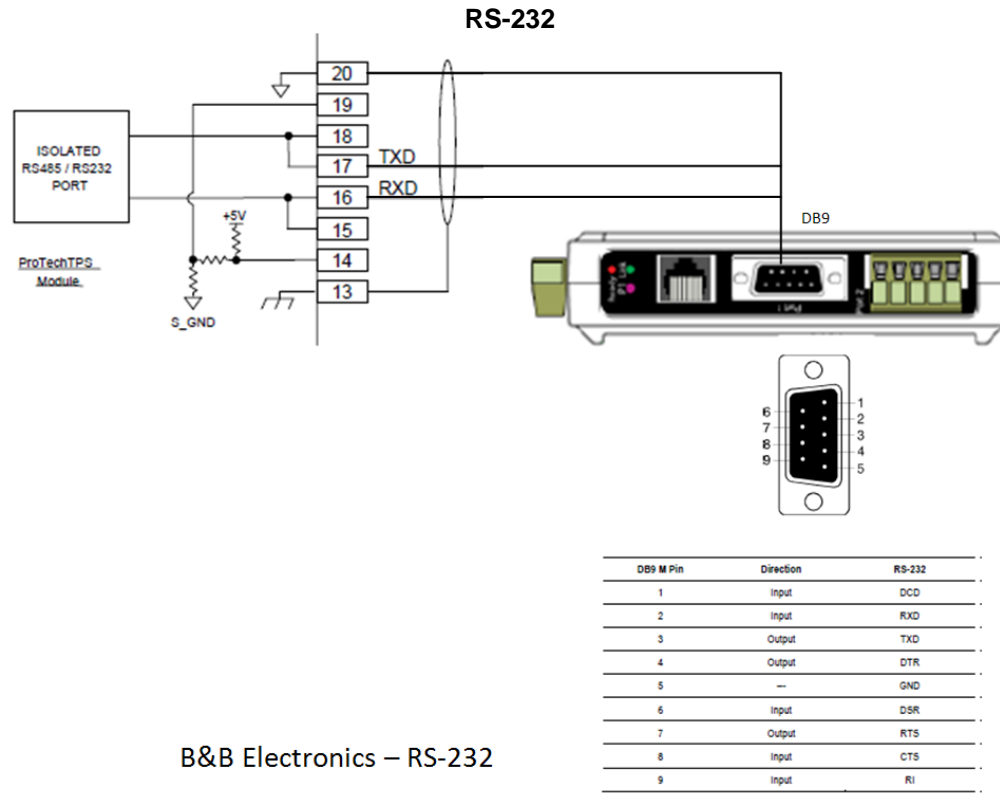

Figure A-1. RS-232 Wiring Diagram

Note: The Serial DB9 connection is used for RS-232 communication only.

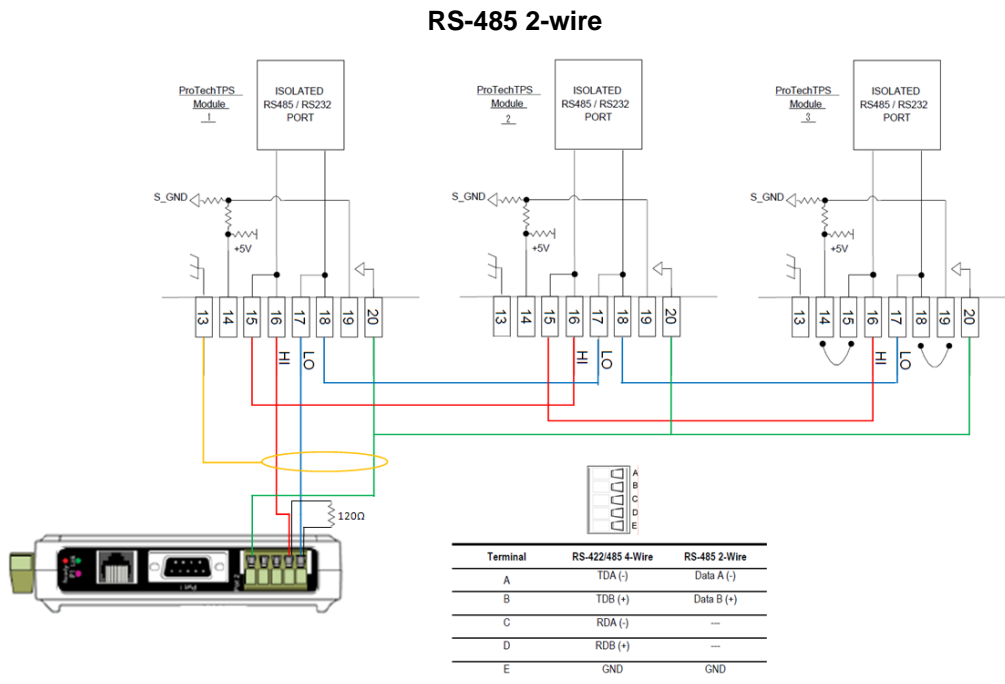

Figure A-2. RS-485 2-Wire

Note: Use the terminal block for wiring of RS-485 communications.

When configuring for RS-485, termination resistors (120 Ω) are needed at each end of the network. Note the location of the resistor on the device. The ProTech has the termination resistor built into the module, jumpers are necessary between terminals 14 – 15 and 18 – 19 to activate the termination.

Configuration –

Configuration of the MESR901 is done through Vlinx Modbus Gateway Manager. The configuration software is provided with the device.

Network Settings

Network

I want DHCP to setup the network.

IP Address:

Subnet Mask:

Default Gateway:

Help

DHCP controls whether or not a DHCP server is used to set the IP address, subnet mask and default gateway of the Modbus Gateway.

When DHCP option is enabled but the DHCP server is not found, the Modbus Gateway will automatically configure an IP address in the range of 169.254.0.0 through 169.254.255.255 with a subnet mask 255.255.0.0.

IP Address field contains static internet protocol address of the Modbus Gateway.

Subnet Mask field contains mask that is used to define sub network.

For Class A network (IP addresses 0.0.0.0 through 127.255.255.255), the default subnet mask is 255.0.0.0.

For Class B network (IP addresses 128.0.0.0 through 191.255.255.255), the default subnet mask is 255.255.0.0.

For Class C network (IP addresses 192.0.0.0 through 223.255.255.255), the default value set mask is 255.255.255.0.

For Class D network (IP addresses 224.0.0.0 through 239.255.255.255) and Class E network (IP addresses 240.0.0.0 through 255.255.255.255), the subnet mask is ignored.

Default Gateway field contains default route to remote networks.

Modbus TCP Settings

Modbus TCP

TCP Client Settings

Connect to Port:

Response Timeout:

TCP Server Settings

Listen on Port:

Limit the number of connections to:

and allow everyone to connect
 and allow a specific IP address to connect
 and allow a specific range of IP addresses to connect

Help

Connect to port identifies TCP port to be used by the Modbus Gateway in TCP client mode. Valid value range is from 1 to 65535.

Response timeout is the maximum amount of time to wait for a response to request that is sent to the device connected through TCP. Valid value range is from 1 to 65535.

Listen on port identifies TCP port to be used by the Modbus Gateway in TCP server mode. Valid value range is from 1 to 65535.

Maximum Clients controls the number of simultaneous TCP clients that can be connected.

Connection Filter Mode controls which TCP clients can connect.

Serial Communication Settings

Vlinx Modbus Gateway Manager 1.3.0

Open Save Search Upgrade Diagnostic Monitor About

Which device do you want to configure? Choose the device by clicking on one of the devices in the list below.

Server Name	Connection	Mac Address
MESR901-000EBE000C38	192.168.1.2	00.0E.0E.00.0C.38

MESR901-000EBE000C38 (192.168.1.2)

Contents

- General
- Network
- Modbus TCP
- Port 1 Serial**
- Port 1 Modbus
- Port 1 ID Remap
- Modbus ID Routing
- Modbus Priority
- Save
- Logout

Port 1 - Serial

Description: Serial Port 1

Mode: RS-232

Baud Rate: 19200

Data Bits: 8-Bits

Stop Bits: 1-Bit

Parity: No Parity

Save Back Next

Help

Description sets the description for this serial port. Maximum length is 32 symbols. Allowed characters are symbols from 'A' to 'Z', from '0' to '9', numbers from '!' to '@' and the space.

Mode controls the physical communications mode.

Baud Rate controls the communications speed of the serial port.

Data Bits controls the number of bits of data in each character.

Only 8 data bits is valid when the protocol of the device connected to the port is RTU.

Stop Bits controls the number of bits to indicate the end of a character.

Parity controls the error checking mode.

Note: For RS-485 communication, select RS-485 under Mode, and use the terminal block connections. The DB9 port is for RS-232 communications only.

Serial Modbus Settings

Vlinx Modbus Gateway Manager 1.3.0

Open Save Search Upgrade Diagnostic Monitor About

Which device do you want to configure? Choose the device by clicking on one of the devices in the list below.

Server Name	Connection	Mac Address
MESR901-000EBE000C38	192.168.1.2	00.0E.0E.00.0C.38

MESR901-000EBE000C38 (192.168.1.2)

Contents

- General
- Network
- Modbus TCP
- Port 1 Serial
- Port 1 Modbus**
- Port 1 ID Remap
- Modbus ID Routing
- Modbus Priority
- Save
- Logout

Port 1 - Modbus

Attached: Slaves

Modbus: RTU

Enable modbus broadcast

Enable 0Bh Exception

Enable serial message buffering

3 Modbus Serial Retries

2000 Milliseconds Modbus Message Timeout

10 Milliseconds TX Delay

Save Back Next Advanced

Help

Attached is selectable between Master and Slaves. If Master is selected, the Modbus Gateway will run in TCP server mode, if Slaves is selected, it will run in TCP client mode.

Modbus indicates the protocol of the device connected to the port. It can be either RTU or ASCII.

Modbus Broadcast is used to send Modbus broadcasts to a specific serial port. Modbus broadcast is Slave ID 0h. If selected the Gateway will send broadcast messages out the serial port and will not expect a response. If unselected it will use slave ID 0h as a standard address.

Modbus 0Bh Exception. When the Modbus slave device does not respond before the timeout has been reached or has a bad response (check sum does not match), the 0Bh exception code is transmitted to the Master that initiated the Modbus message.

Modbus Serial Message Buffering. If option is selected, the gateway will buffer up to 32 message request per port. If this option is unselected, the gateway will respond with a 00h if it has a message out on the port with no response yet.

Modbus Serial Retries is the maximum number of times that the Modbus gateway will retry to send a Modbus message to a Modbus

Lantronix Setup

Below you will find the wiring setup and software configuration for the UDS100-Xpress DR IAP. Remember that the pictures below are for reference, you will need to setup the serial configuration to match the settings you chose in the ProTech. When multi-dropping the 3 modules together using RS-485/422, you will need to assign each module a unique node address, which can be found in the Modbus configuration screen on the ProTech.

Wiring

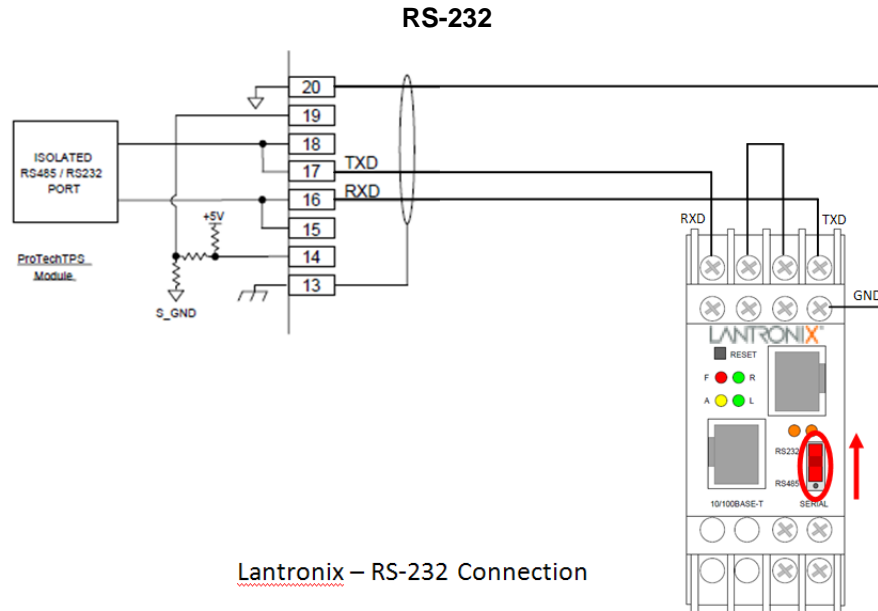

Figure A-3. Lantronix RS-232 Connection

Verify that the dip switch on the front of the device is in the up position, indicating RS-232 communications.

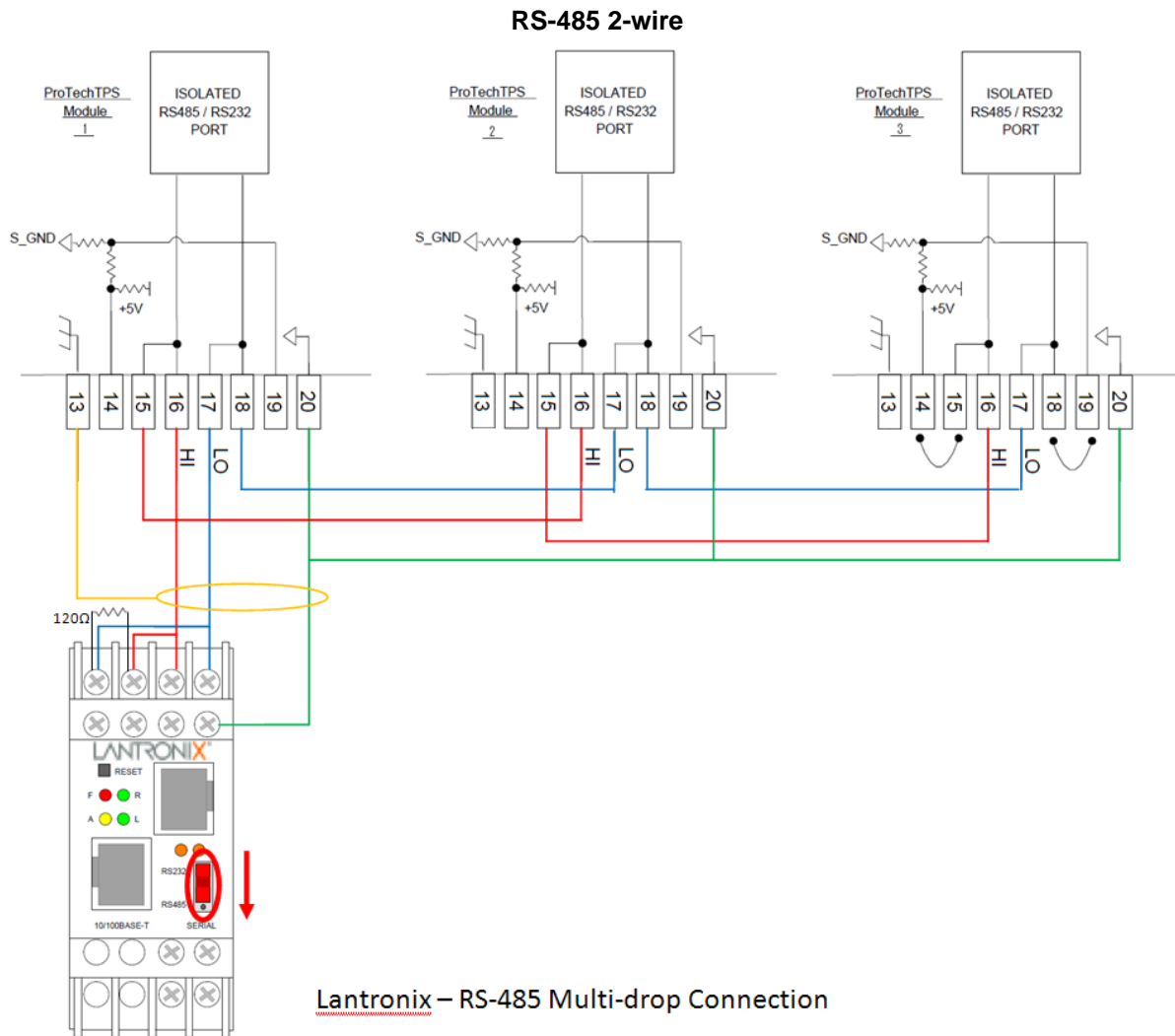

Figure A-4. Lantronix RS-485 Multi-drop Connection

Verify that the dip switch on the front of the device is in the down position, indicating RS-485 communications. When configuring for RS-485, termination resistors (120 Ω) are needed at each end of the network. Note the location of the resistor on the device. The ProTech has the termination resistor built into the module, jumpers are necessary between terminals 14 – 15 and 18 – 19 to activate the termination.

Configuration

Configuration of the UDS100-Xpress DR IAP is done through DeviceInstaller. The configuration software is provided with the device.

Overview

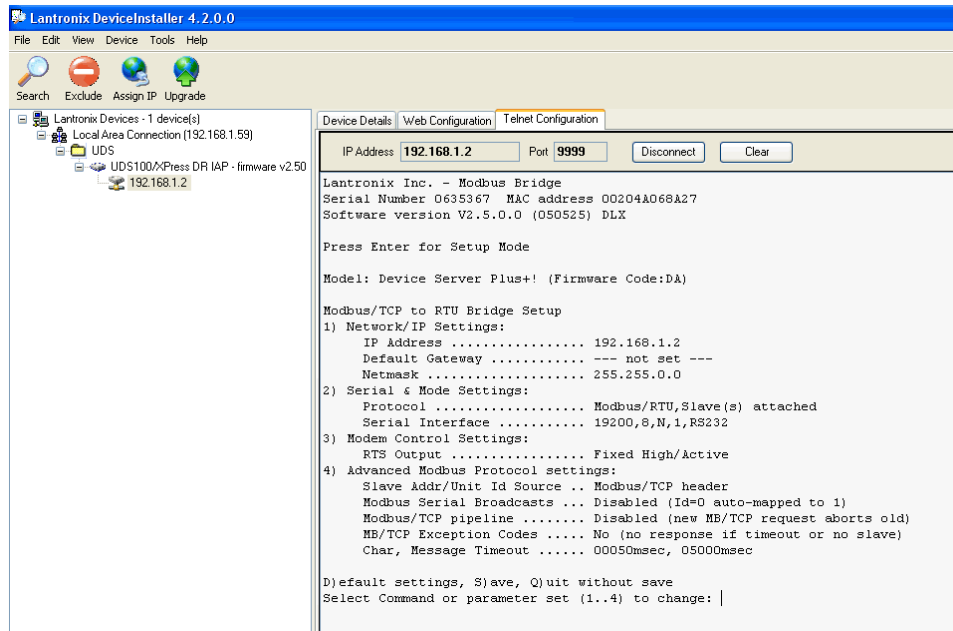

Network Menu

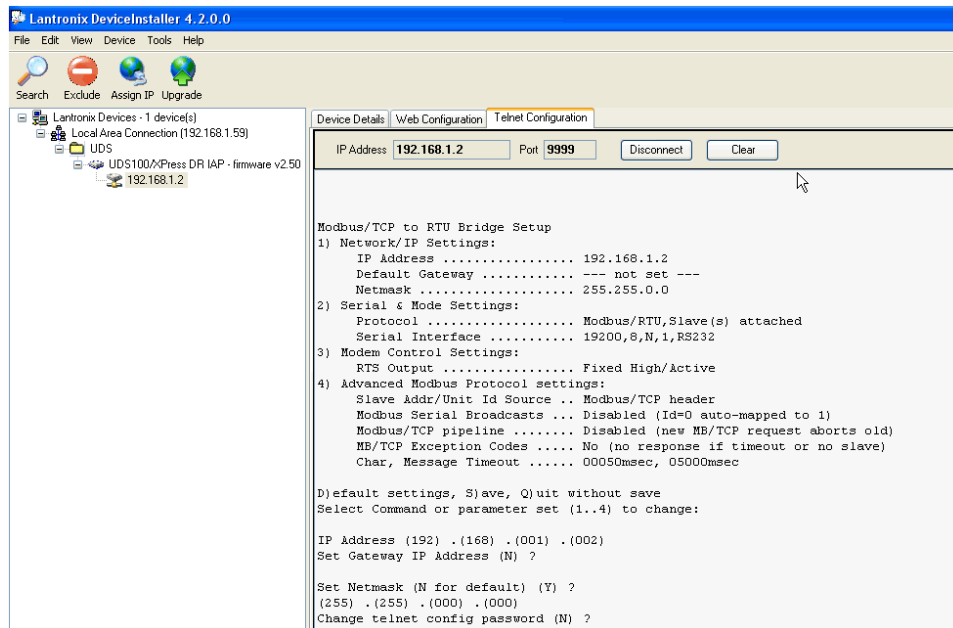

Serial Settings Menu

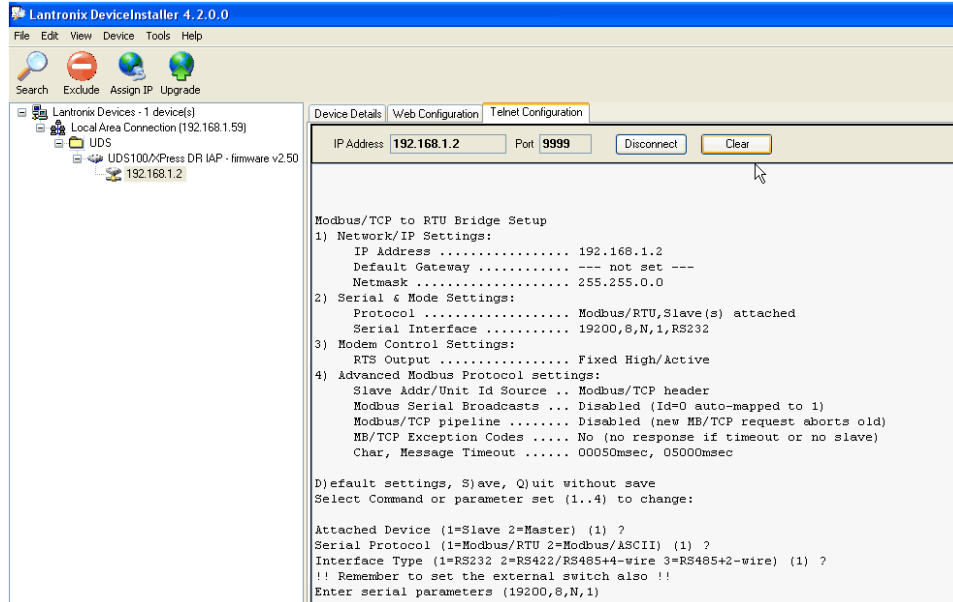

Note: For RS-485 communications, choose option 3 under interface type and don't forget to set the dip switch on the front of the device.

Modem Control Menu

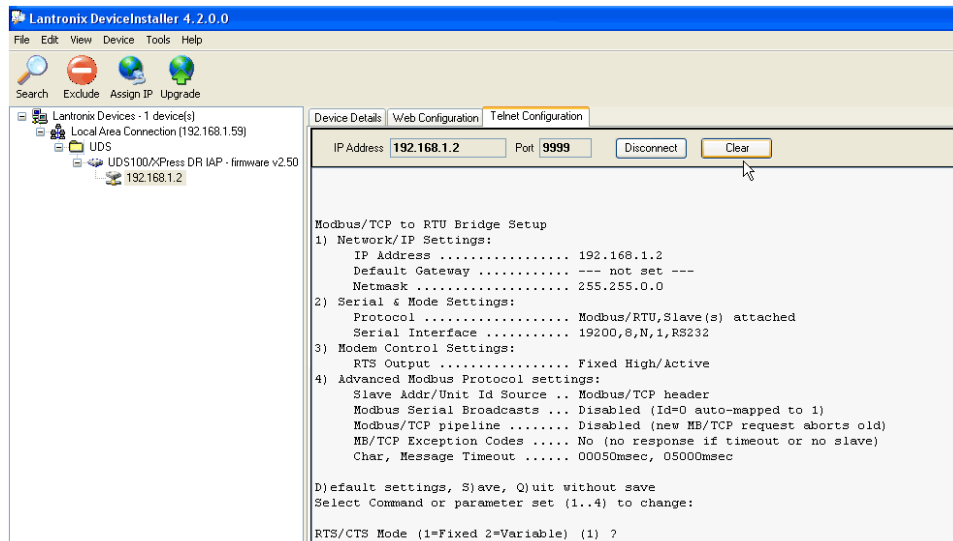

Advanced Menu

Lantronix DeviceInstaller 4.2.0.0

File Edit View Device Tools Help

Search Exclude Assign IP Upgrade

Lantronix Devices - 1 device(s)

- Local Area Connection (192.168.1.59)
- UDS
 - UDS100X/Press DR IAP - firmware v2.50
 - 192.168.1.2

Device Details | Web Configuration | **Telnet Configuration**

IP Address Port

Modbus/TCP to RTU Bridge Setup

1) Network/IP Settings:

- IP Address 192.168.1.2
- Default Gateway --- not set ---
- Netmask 255.255.0.0

2) Serial & Mode Settings:

- Protocol Modbus/RTU,Slave(s) attached
- Serial Interface 19200,8,N,1,RS232

3) Modem Control Settings:

- RTS Output Fixed High/Active

4) Advanced Modbus Protocol settings:

- Slave Addr/Unit Id Source .. Modbus/TCP header
- Modbus Serial Broadcasts ... Disabled (Id=0 auto-mapped to 1)
- Modbus/TCP pipeline Disabled (new MB/TCP request aborts old)
- MB/TCP Exception Codes No (no response if timeout or no slave)
- Char, Message Timeout 00050msec, 05000msec

D) default settings, S) save, Q) quit without save
Select Command or parameter set (1..4) to change:

Slave address (0 for auto, or 1..255 fixed otherwise) (0) ?
 Allow Modbus Broadcasts (1=Yes 2=No) (2) ?
 Use MB/TCP 00BH/00AH Exception Responses (1=No 2=Yes) (1) ?
 Disable Modbus/TCP pipeline (1=No 2=Yes) (2) ?
 Character Timeout (0 for auto, or 10-6950 msec) (50)
 Message Timeout (200-65000 msec) (5000)
 Serial TX delay after RX (0-1275 msec) (0)
 Swap 4x/OH to get 3x/1x (N) ?

Revision History

Changes in Revision H—

- Revised the Regulatory Compliance section
- Revised Figure 2-2a
- Revised Table 4-4
- Added EU DoC

Changes in Revision G—

- Updated RoHS Directive
- Removed WEEE Directive and EuP Directive

Changes in Revision F—

- The following changes were made in the Regulatory Compliance Section
 - New content in the ATEX PED and RoHS Directives
 - Removed WEEE, EuP, and C-Tick Directives
 - Added Australia (&New Zealand) RCM and EMC Compliance

Changes in Revision E—

- Corrected Unit Health Status information (pg 49)

Changes in Revision D—

- Added new warning required by GOST R

Changes in Revision C—

- Updated manual to reflect changes to MPU input threshold and impedance
- Added GOST R information to Regulatory Compliance section

Declarations

EU DECLARATION OF CONFORMITY

EU DoC No.: 00396-04-EU-02-02
 Manufacturer's Name: WOODWARD INC.
 Manufacturer's Contact Address: 1041 Woodward Way
 Fort Collins, CO 80524 USA

Model Name(s)/Number(s): ProTech®SX

The object of the declaration described above is in conformity with the following relevant Union harmonization legislation: Directive 2014/34/EU of the European Parliament and of the Council of 26 February 2014 on the harmonization of the laws of the Member States relating to equipment and protective systems intended for use in potentially explosive atmospheres

Directive 2014/30/EU of the European Parliament and of the Council of 26 February 2014 on the harmonization of the laws of the Member States relating to electromagnetic compatibility (EMC)

Directive 2014/35/EU on the harmonisation of the laws of the Member States relating to the making available on the market of electrical equipment designed for use within certain voltage limits

Markings in addition to CE marking:  II 3 G Ex ec nC IIC T4 Gc

Applicable Standards:

EMC: EN 61000-6-4:2007,
 EN 61000-6-4:2007/A1:2011: EMC Part 6-4: Generic Standards - Emissions for Industrial Environments
 EN 61000-6-2:2005,
 EN 61000-6-2:2005/AC:2005: EMC Part 6-2: Generic Standards - Immunity for Industrial Environments
 ATEX: EN 60079-0, 2018 : Explosive Atmospheres - Part 0: Equipment – General requirements
 EN 60079-7:2015,
 EN IEC 60079-7:2015/A1:2018 – Explosive Atmospheres – Part 7: Equipment protection by increased safety “e”
 EN60079-15, 2010 : Explosive Atmospheres - Part 15: Equipment protection by type of protection “n”
 LVD: EN 61010-1:2010,
 EN 61010-1-2010/A1:2019/AC:2019-04,
 EN 61010-1:2010/A1:2019: Safety Requirements for Electrical Equipment for measurement, control and laboratory use – Part 1 : General Requirements

This declaration of conformity is issued under the sole responsibility of the manufacturer
 We, the undersigned, hereby declare that the equipment specified above conforms to the above Directive(s).

MANUFACTURER

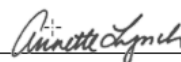

 Signature
 Annette Lynch
 Full Name
 Engineering Manager
 Position
 Woodward, Fort Collins, CO, USA
 Place
 September 15, 2022
 Date

UKCA DECLARATION OF CONFORMITY

UKCA DoC No.: 00396-EU-UKCA-02-02
Manufacturer's Name: WOODWARD INC.

Manufacturer's Contact Address: 1041 Woodward Way
 Fort Collins, CO 80524 USA

Model Name(s)/Number(s): ProTech®SX

Markings in addition to UKCA marking:  II 3 G Ex ec nC IIC T4 Gc

The object of this Declaration is in full conformity with the following UK Statutory Instruments (and their amendments):

S.I. 2016 No. 1107	Equipment and Protective Systems Intended for use in Potentially Explosive Atmospheres Regulations 2016
S.I. 2016 No. 1091	Electromagnetic Compatibility Regulations 2016
S.I. 2016 No. 1101	The Electrical Equipment (Safety) Regulations 2016

The Object of this Declaration is in conformity with the applicable requirements of the following designated standards and technical specifications.

EN 61000-6-4:2007, EN 61000-6-4:2007/A1:2011	Electromagnetic compatibility (EMC) - Part 6-4: Generic standards - Emission standard for industrial environments
EN 61000-6-2:2005, EN 61000-6-2:2005/AC:2005	Electromagnetic compatibility (EMC) - Part 6-2: Generic standards - Immunity for industrial environments
EN IEC 60079-0:2018	Explosive atmospheres - Part 0: Equipment - General requirements
EN 60079-7:2015, EN IEC 60079-7:2015/A1:2018	Explosive atmospheres - Part 7: Equipment protection by increased safety "e"
EN 60079-15:2010	Explosive atmospheres - Part 15: Equipment protection by type of protection "n"
EN 61010-1:2010, EN 61010-1- 2010/A1:2019/AC:2019-04, EN 61010-1:2010/A1:2019	Safety requirements for electrical equipment for measurement, control, and laboratory use - Part 1: General requirements

This declaration of conformity is issued under the sole responsibility of the manufacturer
 We, the undersigned, hereby declare that the equipment specified above conforms to the above Regulation(s).

MANUFACTURER

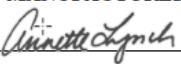

Signature

Annette Lynch

Full Name

Engineering Manager

Position

Woodward, Fort Collins, CO, USA

Place

15-September-2022

Date

We appreciate your comments about the content of our publications.

Send comments to: industrial.support@woodward.com

Please reference publication **26546V1**.



B 2 6 5 4 6 V 1 : H



PO Box 1519, Fort Collins CO 80522-1519, USA
1041 Woodward Way, Fort Collins CO 80524, USA
Phone +1 (970) 482-5811

Email and Website—www.woodward.com

Woodward has company-owned plants, subsidiaries, and branches, as well as authorized distributors and other authorized service and sales facilities throughout the world.

Complete address / phone / fax / email information for all locations is available on our website.